

# Just That Easy: Reactive Power Compensation using the Controller CR4.0

## Installation:

Attach 230V AC to the power supply  $U_B$  pins 5/6 (in any order) of the 24-pin long connector strip. At three-phase systems with 400V AC you may bridge the star (wye) voltage 230V AC (L-N) to the measurement voltage  $U_M$  pins 1/3 (in any order) with the supply voltage. Attach the current transducer to the measurement current  $I_M$  pins 8/9 (in any order); remove the current transducer short (if any). Now half the work is done - the controller CR4.0 is empowered to gauge the net configuration.

One after another attach the branch lines to the capacitor bank to the outputs K1 to K8, pins 11 to 18 of the connector strip (in any order). Attach the phase pole of the 230V AC supply for the contactors of the capacitor bank to the common output COM, pin 10 (or COM2, pin19) and the corresponding neutral to the return paths from the contactors within the capacitor bank. Now the Reactive Power Controller CR4.0 is enabled to compensate the reactive currents in your system by smart activating the capacitors of the bank.

## Commissioning:

For check all lamps of the Reactive Power Controller CR4.0 light for a few seconds when powering up (turn in the controller fuse resp. switch on the circuit breaker). Then the controller is ready for commissioning. The green LED "U (V)" lights and the numerical 7-segment display shows the voltage actually measured. By the "↓" key you may proceed to the next LED "I (A)" while the actual current through the current loop transducer <--> controller (0..5A) is displayed. The numerical display is blinking because the current transducer ratio (ctr) is still unknown (the shown value bases on 5A:5A).

Start the Automatic Self Commissioning process by a long keystroke (3 seconds) on both green arrow keys "↓" and "→" (=reset) or by selecting menu item "In. 2" followed by "SET". While the commissioning process is running the CR4.0 controller switches several times steps of the capacitor bank. It determines from the changes in strength and phasing of current and voltage the net configuration as well as the capacitors reactive powers. That process may take about 5 to 15 minutes. In the meantime the controller displays clocked in sequence "SELF" / "InIt" / "...".

Commissioning is finished when the displayed sequence changes to **"SELF"** / **"InIt"** / **"donE"** followed by lighting all lamps during change to the Automatic Regulation Mode by reset.

If not turned off the sequence **"SELF"** / **"InIt"** / **"..."** is two or three times intercepted by displaying the results of the commissioning process starting with **"APPr"** (for "approve !"; for details refer to chapter "Automatic Self Commissioning" and subchapters beginning on page 9).

If you want to speed up the commissioning process or if you want to track each action you may select special settings prior to start of commissioning. Refer to the following verbose detailed operating instructions. It also comprises the statements necessary for non-standard commissioning.

## Automatic Regulation Mode Operation:

Whilst compensating the reactive power in automatic mode operation your controller CR4.0 shows the obtained power factor  $\cos \phi$  at the numerical 7-segment display indicated by the green LED **"cosphi"** as far as it works nice. The more  $\cos \phi$  approaches 1.00 the less your mains is stressed by reactive current. But note that at low active load the power factor  $\cos \phi$  may achieve any value without relevance because the reactive power is low, too; low load conditions are indicated by no or only one capacitor being switched on.

The green "Steps" LEDs show which steps of the capacitor bank are actually switched on.

During automatic mode operation the mains conditions and the system utilization are tracked by the controller. That gives an extensive collection of actually measured values with their minimum and maximum to be obtained by using the menu tree "Info". The menu tree "Set" offers a multiplicity of settings due to adapt operation, error detection and alarming to your requirements.



SYSTEM ELECTRIC Power Quality GmbH  
Odenwaldstraße 4  
63589 Linsengericht, Germany  
Internet: [www.system-electric.de](http://www.system-electric.de)

Tel.: +49 (0) 6051-74158  
Fax: +49 (0) 6051-71093  
E-Mail: [info@system-electric.de](mailto:info@system-electric.de)

**SYSTEM ELECTRIC Power Quality GmbH**

Author: Werner Weisgerber

# Operating Instructions Reactive Power Controller CR4.0

## **0 Bibliography**

### **0.1 Disclaimer**

This document was written by Werner Weisgerber on behalf of SYSTEM ELECTRIC Power Quality GmbH, Linsengericht, Germany; Copyright ibid.

### **0.2 Scope**

This document applies to Software Version 01.01 et seqq. Edition A1, last change 2018/10/26

### **0.3 Version History**

Edition 1     2018/10/26     First Publication

### **0.4 File**

Name of the original file:     CR40\_EN\_Operation\_0101\_A1 as .doc and .pdf

# 1 Installation

## 1.1 Safety Instructions

**Skilled technical staff only is permitted to mount, connect and commission this reactive power controller. Consider all relevant regulations.**

**In case of visible or assumable damages this controller must not be operated. Only the manufacturer is allowed to repair.**

**This controller is energized by mains voltage and must not be opened. Please note that the clamps can be energized although the regulator is off.**

## 1.2 Installation Diagram

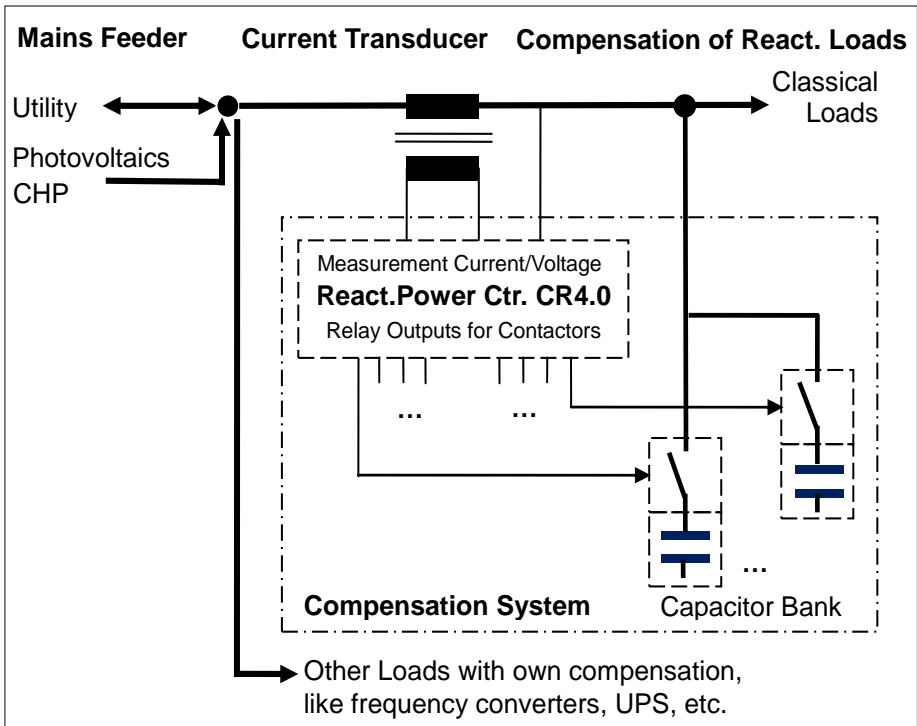

Figure 1 Installation Diagram: Compensation of Classical Loads, only

### 1.3 Connection Diagram

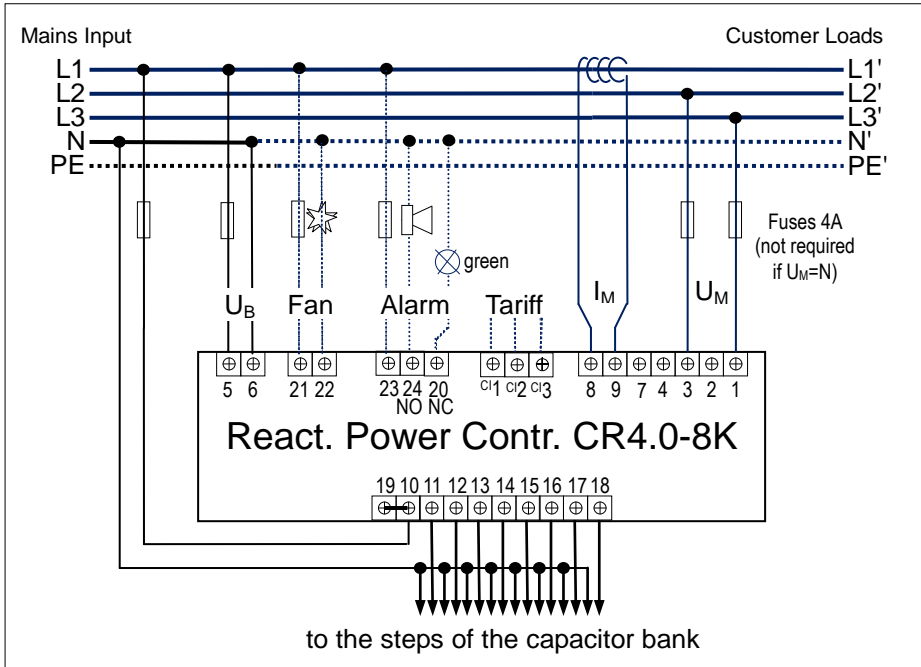

Figure 2 Connections to the Reactive Power Controller CR4.0  
 Please note that pin numbering corresponds to the markings at controller and connector strip rather than to the marking in the connector datasheet !

Figure 2 shows the L-L standard connection diagram. Despite of single-phase current measurement it provides detection of short break at every phase. Short break in phase L1 results in outage of the controller itself by loss of supply. On short break in phase L2 or L3 the controller detects loss of measuring voltage. In every case all steps of the capacitor bank will be immediately switched off due to protect the capacitors from re-connection in phase opposition. Before re-connection the capacitors are discharged during the idle period. Furthermore the response sensitivity of the CR4.0 with L-L measurement is higher by square root of 3 resp. the smallest step power is reduced by that factor.

Please do not feel discouraged to use the simple L-N connection method. Lacking the quoted L-L advantages will be compensated by simplified wiring using bridges for any single phase and for the Null directly at the connector strip. The common pin COM for the contactors should not be included in bridging because of the impacts on measured voltage at contactor switching; experience says that no negative effect results on compensation but harmonics may be recognized slightly increased.

## 1.4 Mechanical Installation

The Reactive Power Controller CR4.0 houses in a panel-mounting case acc. DIN IEC 61554 with a nominal size of 144mm x 144mm.

Usually it is installed into an opening 138mm x 138mm within the door of an electrical cabinet or a compact enclosure. An installation depth of 60mm results using a 90° sideways cabled terminal block connector strip. The housing is locked in the opening by screwed brackets at the left and at the right side.

For DIN-rail installation use the housing variant with the "-H" part identifier. On request you may order gasket rings, or transparent covers with or w/o door lock.

## 1.5 Hints

- The **current transducer** must be placed in-between all left sided feeding equipment and all right sided load equipment including the compensation system itself, see [Figure 1 Installation Diagram](#) on page 4. Loads comprising their own compensation (e.g. frequency converters, uninterruptible power supply UPS, etc.) should not be included in the reactive power compensation.

- **Short bridge unconnected secondary current transducer terminals** when primarily loaded due to protect transducer and service staff from overvoltage harm. Remember to remove the short before controller (re-) activation. General technical regulations suggest single-sided earthing of current transducers at low voltage.

- Low voltage systems with **two or more feeder systems:**

With all feeder and the section switches at the left of the current transducer and all loads to be compensated and the compensation system itself at its right side, see [Figure 1 Installation Diagram](#) a standard compensation system fits.

The 6-transducer-method allows every reactive power controller to handle separate systems using an own reactive power compensation system per transformer but with a section switch in-between. Install each an current transducer at the transformer and at the section switch and use a summarizing transducer for charging the controller. For 2 transformers this sums to 6 transducers. Use different response times for the compensation systems to avoid mutual oscillations.

With two identical transformers and with the status of the section switch as tariff input to the Control Interface (CI) programming the CI allows the CR4.0 to handle that system with only one current transducer per subsystem. Assuming the current is equally distributed in the system the CR4.0 handles two different transducer ratios as a function of the section switch state.

Please ask SYSTEM ELECTRIC for (alternative) solutions.

- The Reactive Power Controller CR4.0 is designed to compensate the reactive current of **classical passive loads**.

**Loads with their own reactive power compensation** (e.g. UPS, frequency converters) can incur mismeasurement on monitoring the steps powers of the own capacitor bank leading to their switch-off. Monitoring the steps powers by the fault analysis is detachable, but you must adopt this task by yourself !

If you have **power generators** (e.g. a photovoltaic plant) installed with the loads **on the right side** of the current transducer (see [Figure 1 Installation Diagram](#)) the Reactive Power Controller CR4.0 is not able to see the current between the loads-sided generators and the loads resp. the capacitor bank. Misregulation and particularly switch-off of steps after wrong steps powers measurement may result. Please correct your installation (it would anyway not be accepted by your utility company nor by the subvention authority).

If the correct installation is not possible or not desired use a second current transducer in front of the generators and a summarizing transducer to charge the difference current into the CR4.0. That avoids misregulation but you must try out whether fault analysis / steps powers measurement has to be detached. In special cases when the generator feeds only active power without reactive contributes you may try the EEA mode in CI menu of the Reactive Power Controller CR4.0.

- When using a **summarizing transducer** the transducer ratio to be programmed in the CR4.0 has to be calculated from the sum of all primary nominal current values divided by the secondary nominal current value of the summarizing transducer. E.g. using two current transducers 1200A:5A and a summarizing transducer 5A+5A:5A gives a setting of  $1200A+1200A:5A= 2400A:5A$  resp. the ratio 480.
- Consider to use the **adequate output power and the adequate cable cross-section** for the current transducer

At current measurement the Reactive Power Controller CR4.0 consumes 0.3VA at 5A from an internal resistance (burden) of 12mOhms (at the -1A variant 90mVA at 1A, 90mOhms). With a maximum of 2.1m cable of 1.0 mm<sup>2</sup> inside the SYSTEM ELECTRIC cabinet the cable from the current transducer must not exceed (values in brackets for the -1A variant):

<b>cable cross-section</b>	<b>2,5VA-transducer</b>	<b>5VA-transducer</b>	<b>7,5VA-transducer</b>	<b>10VA-transducer</b>
1,5 mm <sup>2</sup>	- (100 m)	4,0 m (210 m)	9 m (320m)	13 m (420 m)
2,5 mm <sup>2</sup>	- (170 m)	7,5 m (350 m)	15 m	21 m
4 mm <sup>2</sup>	-	12 m	24 m	35 m
6 mm <sup>2</sup>	-	19 m	36 m	53 m

Table 1 Maximum cable length between current transducer and cabinet including 2,1m 1.0mm<sup>2</sup> (values in brackets for the -1A variant)

The Reactive Power Controller CR4.0 itself is able to handle **secondary-sided transducer overload**, when the system ran for a while with correct load and the overload is creepingly incurred, e.g. by added small machines.

- Measurement bases on analyzing the current and voltage curves versus time. Therefore the accuracy suffers from EMC crosstalk particularly if the common phase for the contactors in the capacitor bank is bridged at the connector strip with the measurement voltage pins. Please **use separate cables for voltage measurement** up to the power bus bar.
- When using **phase shifting components** in the measurement circuits (e.g. old mechanical amperemeter, summarizing current transducer, standard transformer instead of voltage transducer) the resulting measurement fault may be partly corrected by adjusting the parameter "phase error", which at standard is preset for an 1% accuracy current transducer an no voltage transducer.

Note! A transformer to facilitate 230V AC for the contactors must never be used also as voltage transducer because the fluctuating load results in measurement errors by phase and amplitude shifts. Please connect the voltage measurement directly to the power bus bar, use a dedicated voltage transducer, or at least use a separate transformer.

- The measurement circuits as well as the controller's power suply cope with small overvoltages / overcurrents. Due to increase the robustness against heavily fluctuating or high slew rate signals you may attach filtering circuits. The attenuating and phase shifting qualities of that filters must be considered (adjust transducer ratios and phase error parameters). When adding a filter into an operational system please perform new commissioning afterwards.
- **Reactive Power Compensation and Emergency Power Supply:** Usually it is recommended that a stationary emergency power plant should not be stressed by a reactive power compensation. The diesel generator itself is able to provide any reactive power needed. For this the emergency power plant has to be connected at the right side of the current transducer, see [Figure 1 Installation Diagram](#). Then the reactive power compensation plant automatically idles when the emergency power plant takes over from the utility feeder.

Emergency power supply from the public utility is accomplished using an increased frequency (51Hz / 61Hz). Here it is not intended to switch off the reactive power compensation plant. If your utility company claims switch-off the SYSTEM ELECTRIC service staff can change the internal alarm parameters for frequency accordingly.

- The Reactive Power Controller CR4.0 is not especially designed for use in **isolated networks**, in particular not for networks with a regulation strategy differing from that of the public utility. Usage for that cases is at own risk resp. works on agreement with SYSTEM ELECTRIC (e.g. fishing ships, oil rigs).



## 2 Commissioning

The Reactive Power Controller CR4.0 is equipped with the function **automatic self commissioning**. In Standard Mode all relevant settings will be evaluated by the controller itself; the user is supposed to enter the current transducer ratio that cannot be identified without external aid, and the detuning factor. A factory pre-programmed controller (=SE Mode) comprises all data known from compensation system assembly; during commissioning data will be complemented and checked against reality.

Using the experts menu all stages of commissioning may be executed one after another as well as manually be programmed. Special prerequisites or supplementary data can be programmed with the experts menu.

In commissioning mode the green "Auto" LEDs "cos phi" and "THDU" in the left side vertical LED menu ribbon cannot be reached because usually the prerequisites for calculation are unknown until commissioning is finished. The left side vertical LED menu begins with "U (V)" of the green "Auto" LEDs; Readings and step based data are not valid until all settings have been established, e.g. the current transducer ratio. In commissioning mode no min/max readings are stored and alarms are suppressed until the respective prerequisites are available. For alarms already reported see chapter [5.5 Alarm Types \(Summary\)](#) on page [59](#).

### 2.1 Automatic Self Commissioning

A manual reset by a long (3 seconds) keystroke at the same time on both green arrow keys "↓" and "→" or launching menu item "In. 2" in menu tree "Set" by the "SET" key starts the automatic self commissioning process.

Note that automatic commissioning does not start self-acting after the reset for aborting a commissioning in progress neither, by power-on due to enable the equipment installer and the commissioning specialist to independently work at separate sessions.

During the automatic self commissioning process the clocked text ribbon "**SELF**" / "**InIt**" / "... " is shown at the numerical 7-segment display, please wait. When available the result of every stage of the commissioning process is displayed beginning with "**APPr**" (for "approve !"). By parameters result presentation that may be suppressed or the "**SELF**" / "**InIt**" / "... " text ribbon may cease due to show every single result from step switching (not wise if the transducer ratio had not been entered).

The automatic commissioning process is finished when the text ribbon changes to "**SELF**" / "**InIt**" / "**donE**" and the controller passes to the automatic regulation mode via reset, indicated by all lamps lighting for a few seconds (=lamp test).

In the automatic self commissioning process the controller switches steps of the capacitor bank due to calculate the net configuration and the steps powers from the changes in strength and phasing of current and voltage. If you detect any abnormality or if you want to abort an unintendently started commissioning process, at any time strike the "ESC" key. Please confirm the security query "SurE" / " " to " / "Abrt" (=Sure to Abort ?) with "SET" to abort the commissioning process or answer with any other key for resume.

### 2.1.1 Automatic Self Commissioning in Standard Mode

In the Standard Mode of automatic self commissioning the Reactive Power Controller CR4.0 finds out by switching steps of the capacitor bank:

- The **connections** between controller and mains network ("net configuration").

For that the controller determines the **phase angle** in degrees from the relative phasing and polarity of the measuring current with respect to the measuring voltage. For conversion of connections to angle see [Table 3: Pin Assignment versus system dependent Phase Angle](#) on page 44.

Additionally the **nominal mains voltage** / reference voltage for steps powers correction is calculated from the measured voltage and the net configuration L-L or L-N and fined to a standard voltage. Then the **reference frequency** is fined (usually either 50Hz or 60Hz) from the frequency just measured.

The result of gauging the net configuration is displayed like the following: "**APPr**"/"**ConF**"/" **0.67**"/"**180°**"/" **400**" = approve net configuration: actual  $\cos \phi = 0,67$  (cap/ind according to LED), phase angle = 180° (=e.g. N-L1; L1 k-l), nominal mains voltage = 400V.

Fining the nominal mains voltage uses a table fixed in the controller SW. E.g. a measuring voltage of 223V in a L-N configuration gives the usual nominal mains voltage 400V and internally a nominal measuring voltage of 231V. All steps powers are stored at nominal standard conditions due to use always the corrected power values in case of differing and fluctuating actual voltages or frequencies. Thus the nominal mains voltage needs to be strictly observed.

If e.g. the controller is applied to collapsing networks in India an actual measuring voltage of L-N 214V results in a nominal mains voltage of 347V instead of desired 400V. Then all steps powers are sized deratedly by 25%. Please correct the nominal mains voltage for correct power display.

- The **Steps Powers** for all 8 possible steps:

The sizing process may last 10 minutes because 5 cycles at least (typ. 7) have to be completed. To speed up the last step number in use may be programmed.

The result of sizing the steps powers is displayed like the following: "**APPr**"/"**SIZE**"/" **200**"/" **24**"/" **26**"/" **50**"/" **49**"/" **51**"/" **-**"/" **-**"/" **-**" = approve step sizes: total power of the capacitor bank =200kvar consisting of 2 steps of about 25kvar and 3 steps of about 50kvar. While showing the size of one step the respective "Steps" LED is quickly blinking in red and if not all steps are capacitive the "Cap"/"Ind" LEDs indicate the steps types. The chain of values ends early if the last step number in use has been programmed.

### 2.1.2 Automatic Self Commissioning with a Pre-programmed Controller

During automatic self commissioning with a factory pre-programmed controller the Reactive Power Controller CR4.0 finds out by switching steps of the capacitor bank:

- The **connections** between controller and mains network ("net configuration"). Same procedure and same result display as in Standard Mode.
- The **Current Transducer Ratio**:

Long time before the measure results of step sizing are enough for calculating the individual steps sizes the measure results in total are enough to calculate the **current transducer ratio (ctr)** as quotient of pre-programmed steps sizes in kvar and the measured change in the network in internal units.

The result of the current transducer ratio evaluation is displayed like the following: "**APP**r"/"**I.ctr**"/" **120**"/"**I.tot**"/" **327**" =approve current transducer ratio and total current: current transducer ratio =120 (e.g. 600A:5A), total current =327A. The total current value allows to quickly check the result because most customers have an amperemeter in their premises.

If no current transducer had been pre-programmed or if the pre-programmed and the measured values are the same and if on the other side all so far measured steps sizes match the pre-programmed values within a small tolerance then immediately or after only a few further step switchings the result of steps sizing is displayed as in Standard Mode.

Every pre-programmed step is switched once at least due to detect unwired control lines or missing power fuses. If any mismatch is detected in current transducer details or in steps sizes automatic self commissioning leaves the path for pre-programmed controllers and continues automatic self commissioning in Standard Mode, indicated by the text ribbon "**ModE**" / "**SELF**" / "**Std.**". All 8 steps will be sized retaining all single measure results so far.

Pre-programming the controller speeds up commissioning because only the net configuration, and the current transducer ratio (ctr) have to be measured and the steps sizes only have to be checked. On mismatch between the measured ctr and the pre-programmed ctr a text ribbon is shown like "**APP**r"/"**SELF**"/"**I.ctr**"/" **120**"/"**I.tot**"/" **327**"/"**HAnd**"/"**I.ctr**"/" **100**"/"**I.tot**"/" **272**" =approve current transducer ratio and total current measured ("SELF"): ctr =120 giving a total current of 327A against the pre-programmed ("HAnd") values: ctr =100 resulting in a total current of 272A. With the amperemeter in the customer premises or using a clamp-on amperemeter you can easily decide which ctr is the right one. Meanwhile the controller uses the pre-programmed ctr for completion of the commissioning; later when in automatic regulation mode or when repeating commissioning you get the chance to correct the ctr, if necessary.

Controller generated ctr are fined by a table fixed inside the SW with usually known ctr's.

- The steps powers for all pre-programmed ( / for all steps): Same result display as in Standard Mode.

### 2.1.3 Pre-programming the CR4.0 (SE-Mode)

Switching on or off the factory pre-programmed mode (SE-Mode) has to be done prior to any setting of parameters or steps data because different internal representation of values are used. Therefore some settings or data are cleared when changing the SE-Mode ex post.

SE-Mode is switched on (" On") or off (" OFF") by the menu item "**In. 3**" in the experts menu of commissioning.

When SE-Mode = off entering steps sizes by hand requires the net configuration and the current transducer ratio to be known due to convert the kvar units at input into the internal digits that saves the 16-bit microprocessor from straining 32-bit calculations. The Reactive Power Controller CR4.0 becomes factory pre-programmed by entering by hand all known settings or data (at least one step size) when SE-Mode = on; because of a special conversion factor for steps sizes there are no prerequisites for that. When net configuration and current transducer ratio have been evaluated the controller replaces the SE-Mode data by the special internal data format used for operation.

### 2.1.4 Non-Standard Compensation Systems

The parameter settings and data for a special compensation system different from standard capacitor systems have to be entered in the [Experts Menu](#) (page [13](#)) resp. in SE-Mode ([Pre-programming the CR4.0 \(SE-Mode\)](#) (page [11](#)) prior to commissioning start, e.g. inductive steps by menu item "St.yy" or by "In. 7" which is forwarded to "St.yy".

### 2.1.5 Special Settings or Guidelines

- **Detail Info:** You can set the quality "detail info" by entering the password "4444" or set or reset that quality with menu item "In.18". When on during commissioning you can see every single measuring result as it occurs instead of the stupid text ribbon "SELF" / "InIt" / "... " (or "ConF" resp. "SIZE" instead of "InIt" in experts mode). For steps sizes reasonable results will only be shown if the current transducer had been entered prior.
- **Inductive Steps:** The Reactive Power Controller CR4.0 is able to handle mixed compensation systems with capacitive and inductive steps. Also the 2/3 hysteresis is separately handled. The types of the steps has to be set prior to commissioning using menu item "St.yy" or "In. 7".
- **Voltage Transducer:** A voltage transducer must be entered by hand prior to commissioning. If you fail to do so the nominal mains voltage will not be correct when changing the voltage transducer ratio afterwards. For input at the green "Auto" LED "cos phi" refer to "U (V)" on page [32](#) in paragraph [5.2.1.1 Green "Auto" LEDs and yellow "Service" LED "ΔQc": Direct Presentation of a Measured Value.](#)

## 2.2 Experts Menu

With the experts menu you can execute all stages of the commissioning process under your control as well as perform commissioning with special settings. Also you are able to commission the Reactive Power Controller CR4.0 completely by input by hand. The section "In " within the menu tree "Set" forms the experts menu, see chapter [5.4.4 "Set" Menu Group Initiation \("In. "\)](#) on page [42](#), aided by the other "Set" sections.

It seems as if some items of this menu group are needless because they are the same as other menu items. Note that the planned Basic variant of the Reactive Power Controller CR4.0 does not include the large, sophisticated 2-dimensional menu groups of the "Info" and "Set" menu trees.

## 2.3 Error Codes and Tips

### Error Codes

During Commissioning all alarms may be reported like in automatic regulation mode as far as the preconditions are given (e.g. the threshold of alarms AL.11/12 Under-/Overvoltage are relative to the nominal mains voltage and cannot occur until that voltage is set by gauging the net configuration. In contrast alarms AL.16/17 Under-/Overvoltage relating to the metering capacity always may unrestrictedly occur. Please note that Undervoltage alarms are suppressed until commissioning start due to allow controller pre-programming on desk with only the supply voltage connected).

For alarms see [5.5 Alarm Types \(Summary\)](#), on page [59](#).

Besides that commissioning may result in error without any suitable alarm. That error codes on commissioning are:

- "Err.1" Process aborted by user ("ESC" key)
- "Err.2" Changing to automatic regulation mode not allowed: net configuration is unknown / ...
- "Err.3" ... / steps powers are unknown (error code is displayed after activating menu item "In.15" Change to automatic regulation mode)
- "Err.4" No current metering / no populated staep at all. Check the current transducer short being open, check cabinet wiring !
- "Err.5" Changing to automatic regulation mode not allowed: SE Mode active
- "Err.6" Presetted catenation factor (L-L oder L-N) does not match the system
- "Err.7" Timeout during gauging the net configuration
- "Err.8" Timeout during sizing of steps
- "Err.9" Current transducer ratio not suitable for the system's size (SE Mode)

## Tips

- Do not start automatic self commissioning until you have checked that metering works: Approve voltage and current readings with the green "Auto" LEDs of the left sided LED menu ribbon (while no current transducer ratio entered the "I (A)" LED blinks and the current reading bases on 5A resp. 1A).

If that readings are not plausible at first check the connections, in particular the fit of the connector strip. Regardless of mode you may switch steps in manual mode, see (sub-)chapters (of) [3.2 Manual Mode](#) on page 17, and observe the changes in total currant, but note the total current may decrease when switching a step on because of compensation effect. At a total current less than 40mA (related to the 5A scale) commissioning additionally uses steps of the capacitor bank as pre-load.

- By enabling the Detail Info (Password 4444 or menu item "In.18") the commissioning process can be traced / supervised stage by stage. (This setting survives the next reset and should be checked / again enabled when often repeating the commissioning process.)
- In common already evaluated net configuration or steps sizes results are preserved until a subsequent commissioning process provides new results. Thus you may rescue settings and data by early removing the controller's supply voltage if you suppose that the actual commissioning will fail.
- **Please do not get impatient !** The Reactive Power Controller CR4.0 is designed to have all commisioning results unchangably constant when proceeding to the automatic regulation mode. Thus when the commissioning specialist leaves customers premises nothing will change thereafter. Achieving final settings and data may require up to 15 minutes.

Other Reactive Power Controllers with fast commissioning evaluate the steps sizes only with low accuracy during commisioning. Within the next few days the accuracy is enhanced during automatic regulation operation. Thus strictly the commissioning specialist has to come back after some days due to check the final settings and data.

- **Commissioning by Hand** is done using the experts menu, section "In " within the menu tree "Set", see chapter [5.4.4 "Set" Menu Group Initiation \("In. "\)](#) on page 42, aided by the other "Set" sections. The menu items within "In " are arranged in the order as they are worked-off at automatic self commissioning up to the menu item "In.15" (Change to the Automatic Regulation Mode).

If however the settings are done in other sequence then changing to the automatic regulation mode by menu item "In.15" may get refused with the missing data error "Err.2" or "Err.3" although every setting or data needed had been evaluated. That is a result of the wrong sequence but will be forgotten if you again use menu item "In.15" after the reset following the error acknowledge.

## 3 Normal Operation

After completing commissioning with success the Reactive Power Controller CR4.0 enters normal operation in the Automatic Regulation Mode "Auto".

Normal operation comprises other operation modes: Manual Mode "Man", and Shutdown "StoP". All of those operation modes include the sub-mode Alarm Switch-off "-AL-" where all steps of the capacitor bank are switched off due to protect them from dangerous impacts e.g. overvoltage.

For alarms see [5.5 Alarm Types \(Summary\)](#), on page [59](#).

### 3.1 Automatic Regulation Mode

In the Automatic Regulation Mode the controller always attempts to adjust the reactive power in the mains network such that the target cos phi is achieved.

After starting the controller in automatic regulation mode by reset or change of operation mode the controller pauses for the idle period of contactors even with thyristor switches. Besides standard idling, see chapter [3.1.4 Idle](#) on page [17](#), this pause prevents from disturbances in mains network when all devices start altogether. Calculation of min/max values is suspended for twice the idle period.

The automatic regulation consists of two algorithms. The regulation algorithm permanently monitors the mains network and calculates the demand for additional reactive power necessary to reach the target cos phi. The switching algorithm calculates the floating mean of reactive power demand and causes after a demand-dependent response time steps of the capacitor bank to switch on / off.

#### 3.1.1 Regulation Algorithm

The momentary values of measuring voltage and current are sampled some thousand times a second by an analog to digital converter. That samples are stored in relation to time in the microprocessor memory. Using fourier analysis the regulation algorithm calculates the RMS readings, and the phasing of the fundamental and the power shares of the fundamental and the harmonics. As the result of the regulation algorithm a number of times per sinus cycle the actual values of active and reactive power in the mains network are provided for further processing.

From that the averaged measurement readings are calculated as well as derived quantities (e.g. the actual cos phi) for being displayed and for min/max evaluation.

Considering the target  $\cos \phi$  the regulation algorithm calculates from the actual readings the demand of additional reactive power for compensation. This calculations incorporate the projection to nominal mains voltage and nominal frequency due to respect changing steps powers at non-nominal network conditions.

Note: At very small active power the  $\cos \phi$  is not usable for regulation because its value may jump anywhere within a wide range due to the granularity of the capacitor bank and is even undefined at zero active power. Thus the regulation algorithm internally uses power values rather than  $\cos \phi$ .

### 3.1.2 Switching Algorithm

Periodically the actual active power and the demand of reactive power are averaged by the switching algorithm weighted due to particularly prefer the more recent values. When the mean demand exceeds  $2/3$  of the smallest step power in the capacitor bank (=hysteresis power, separately provided for switching on resp. off and for capacitive resp. inductive steps) the switching algorithm selects after the demand-dependent response time which steps to switch on or off due to adjust the  $\cos \phi$  towards its target value.

Considering how often a step had been switched on so far and how long a step was under voltage the selection algorithm attempts to make as less state changes as possible due to produce low disturbances in mains network and to prevent from hang-up because to many steps are idling after being switched off.

The regulation algorithm already considered the steps powers effective in network that change with actual mains voltage and actual frequency.

The switching algorithm results in a reactive power in the mains network that -if ever possible- exceeds or undercuts the reactive power required for the target  $\cos \phi$  by less than  $2/3$  of the smallest step power in the capacitor bank.

Note that if you have to care for no capacitive power in mains network, refer to paragraph [Not any Regulation into Capacitive Cos Phi](#) on page 72, then the inductive resp. capacitive excess may be other distributed. Their sum indeed is always  $4/3$  of the smallest step power.

### 3.1.3 Response Time, Response Time Dynamics

After a change of reactive power demand from an entirely compensated network (i.e.  $\cos \phi = \text{target } \cos \phi$ ) sized two times the smallest step power or more the controller will respond with a new switching combination of the capacitor bank after the response time set as a parameter, For smaller demands the response time dynamik delays the response by up to about ten times for a demand of  $2/3$  of the smallest step power. A reduction of response time is not installed.

But note that the programmed response time can be undercut if the switching algorithm is pre-loaded by a small demand but due to response time dynamics the time was yet not sufficiently "mature" for switching.



### 3.1.4 Idle Period

Contactors connect a capacitor to the mains network randomly at any point in the sinus phasing. Thus if the connection is made at voltage maximum and the capacitor is still loaded to voltage minimum because of the last switching off at that point in phase then switching on takes place in opposite. Such a contact results in an extreme inrush current that especially at high ambient temperature could overstress the capacitor to partly being damaged or even to its death.

Due to avoid switching in opposite the capacitor will always discharge by a small resistor network when not connected to the mains. Usually the resistors provide discharge to less than 50V in one minute what is at least required from charged big capacitors for protection of persons. When connecting a discharged capacitor to the mains network the worst power at switching on at maximum voltage is only one fourth of that switching in opposite.

At the CR4.0 the idle period for contactor switching defaults to 45 seconds.

For inductive steps as well as for thyristor switched steps no idle period is required. Nevertheless this idle period can be changed from the default 0 to some seconds if desired.

Immediate after starting the controller in automatic regulations mode by reset or change of operation mode the controller pauses for the idle period for contactors even with thyristor switches. This pause prevents from disturbances in mains network when all devices start altogether. During commissioning step idling always works as if all steps are populated with contactors.

## 3.2 Manual Mode

In Manual Mode the automatic regulation pauses to switch the steps. Instead the service staff can switch any configuration of the capacitor bank by hand. This way even defective or unpopulated steps can be switched on. Still the idle period for contactors with capacitive step power is recognized as well as switch-offs due to alarms.

### 3.2.1 Enter the Manual Mode

Manual Mode is available in every mode of Normal Operation as well as in Commissioning. From the menu item "**Man**" in the left sided vertical LED menu ribbon strike the "SET" or the "→" key to enter Manual Mode. If the service password has been set entry to manual mode is password protected. The yellow "Man" LED of the left sided vertical LED menu ribbon flashes very fast for a few seconds if entry to manual mode is forbidden.

The Reactive Power Controller CR4.0 works in manual mode when the **yellow LED "Man"** in the left side menu ribbon **blinks**

On entry into manual mode the switching state of the capacitor bank remains unchanged but can be changed using the keys

### 3.2.2 Manually Switch Steps (Action Menu)

After entry into manual mode step 1 is selected for switching indicated by the "Steps" cursor is flashing (fast blinking) at "1" within the red "Steps" LEDs ribbon. Use the arrow right key "→" to select the next step indicated by it's red LED is flashing. Between wrap around from the last step to the first one there is a state "no man's land" where no step is selected. From there you can temporarily leave the manual mode.

When you have selected any step you can toggle its state on / off using the "SET" key as well as the arrow down key "↓". The step's green LED indicates the on-state. The step's red LED flashes very fast for a few seconds if the switch-on command had been rejected e.g. due to capacitor idle period, due to an alarm switch-off "-AL-", or due to a single step switch-off because on calculated resonance.

You may switch on unpopulated steps and even defective steps. It is possible to switch both, capacitive and inductive steps to the on-state. The user himself is responsible to avoid resonance effects. Note that single step switch-off due to calculated resonance as well as common alarm switch-off "-AL-" has precedence over the manual mode and switches the affected steps off and prevents them from switch-on. The step's red LED flashes very fast for a few seconds if a switch-on command had been rejected

Any switching state of the capacitor bank remains unchanged until changed by hand. The controller itself is not empowered to switch steps on but can switch single or all steps off due to calculated resonance or due to alarm switch-off. Any step switched off by the controller remains off even if the reason is cleared.

### 3.2.3 Temporarily leave the Manual Mode

Within the manual mode action menu the step selected for switching is indicated by it's red flashing LED. Use the arrow right key "→" to select the next step. Between wrap from the last step to the first one there is a state where no step is selected. From there you can temporarily leave the manual mode.

In the "no man's land" the cursor in fact has returned to the yellow "Man" LED in the left sided vertical LED menu ribbon; the numerical 7-segment display shows "MAN". With the arrow down "↓" key you can proceed the cursor within the left sided vertical menu to the next menu item "Set".

You can reach every menu item with the manual mode still active in background. A few menu items particularly in the "Set" menu tree refuse parameter change or action start because they are not allowed during manual mode, e.g. repair / exchange or repair / add step (but repair / check is allowed). Outside the action menu of manual mode the "Steps" LEDs are used by the particular menu items.

### 3.2.4 Standard Screen in Manual Mode

After 3 minutes without any keystroke and without long term action the controller falls back into the standard screen. While manual mode is active (indicated by the

blinking yellow "Man" LED in the left sided vertical LED menu ribbon) the menu cursor is set to the blinking yellow "Man" LED in the left sided vertical LED menu ribbon; the numerical 7-segment display shows " MAn".

Use the "SET" or the "→" key to enter the action menu of manual mode; if password protected you may need to enter the service password. The arrow down key "↓" proceeds the menu cursor downwards to "Set" (=temporarily leaving the manual menu).

### **3.2.5 Screens shown in Manual Mode**

The manual mode is active whilst the yellow "Man" LED in the left sided vertical LED menu ribbon is blinking.

The numerical 7-segment display shows " MAn" if the menu cursor resides at the yellow "Man" LED in the left sided vertical LED menu ribbon. From there you may enter the action menu of the manual mode by the "SET" or "→" key. Within the action menu the numerical display shows the current cos phi and besides the blinking "Man" LED no other green or yellow LED is active.

If any other green or yellow LED is active then you have temporarily left the manual mode and the menu cursor resides at that LED or inside one of the "Info" or "Set" menu trees if the respective LED is blinking.

### **3.2.6 Terminate the Manual Mode**

Due to terminate the manual mode strike the "ESC" key in the standard screen (when the menu cursor resides at the yellow "Man" LED in the left sided vertical LED menu ribbon and the numerical 7-segment display shows " MAn"). Termination of the manual mode may require the service password if protected.

Immediately after the manual mode is finished all defective or unpopulated steps are cleared to the off-state. Also combinations not valid for the restored operation mode are cleared. All valid parts of the capacitor bank switching state remain unchanged until actively changed by regulation that start after one capacitor idle period for contactors.

### **3.2.7 Reset in Manual Mode**

Following reset or supply power-on the Reactive Power Controller CR4.0 again starts in manual mode. However the switching state of the capacitor bank prior to that event has become lost. At startup all steps once pause for the idle period of contactor switched steps even if thyristors or inductive steps are populated.

### 3.3 Out of Operation (STOP)

The Reactive Power Controller CR4.0 terminates operation on emergency stop (i.e. both red keys "ESC" and "SET" are struck at the same time for 3 seconds) or if an alarm cluster occurs e.g. by pendular alarms resp. resets. While in commissioning mode no out of operation can occur nor is it essential because the controller itself never switches steps on.

Automatic regulation stops and all steps switch off. At times the controller shows "StoP" at the numerical 7-segment display. However it is possible to enter repair or to enter manual mode and switch steps on; after termination of manual mode all steps will be "cleaned" to off. Following reset or supply power-on the Reactive Power Controller CR4.0 again starts in out of operation mode but manual mode terminated.

Due to re-start operation strike both green arrow keys "↓" und "→" at the same time for 3 seconds. Note: Because the arrow keys lie very close together service staff with thick fingers has to use one finger each of both hands.

### 3.4 Alarm Switch-off

All normal operation modes and commissioning include the sub-mode **Alarm Switch-off**. This sub-mode prevents the capacitor bank from damages by excessive net conditions by switching off all steps and prevent them to be witched on.

Alarm switch-off is initiated by any alarm in the range "AL.10" to "AL.27" (see [5.5 Alarm Types \(Summary\)](#), on page 59). That comprises those alarms that are associated with a danger for the capacitors, e.g. over / under-voltage, overcurrent, excessive harmonics, excess-frequency, over-temperature or failure of the controller's power supply. Alarm switch-off is indicated by "-AL-" in the numerical 7-segment display.

The alarm switch-off terminates when all reasons for the associated alarms have been removed. Note that an acknowledge to any alarm only removes that alarm from presentation but does not terminate that alarm. Thus the alarm switch-off will still remain until the alarm reasons are finished in fact; any still active but acknowledged alarm ist indicated by "AL..." and may be re-displayed using menu item "C0. 8".

Note that alarm recognition as well as recognition of alarm termination may be delayed for more than the de-bouncing period, e.g. voltage harmonics 5 minutes (standard) for alarm on and 15 minutes for alarm off, or over-temperature 1/4 hour (standard) for on/off with a hysteresis of 13°C.

Besides the alarm switch-off comprising all steps there exists a single step switch-off for affected steps due to (calculated) resonance ("AL 8") or due to steps power loss >20% (standard) ("AL.31" for step 1 to "AL.38" for step 8).

### 3.5 Alarms

Besides the Common Alarms "AL. 1" and "AL. 2" there exist the alarming notices "AL. 3", "AL. 4", "AL. 9" and "AL.60", the steps related alarms "AL 8" and "AL.31" to "AL.58", and the alarms associated with alarm switch-off "AL.10" bis "AL.27" (see [Table 4: Alarm Types](#) on page [60](#)),.

Most of the alarms are indicated by one of the red alarm LEDs within the left sided vertical LED ribbon.

In combination with the red alarm LED "Step" one or more of the red LEDs within the horizontal LED ribbon "Steps" indicate(s) the affected step(s). A continuous lighting LED stands for a step switched off and out of service (with constant red the green LED indicating a step switched on would not be possible) while a slowly blinking red LED stands for a step that is still (restricted) functional.

The menu cursor of the left sided vertical LED ribbon can be placed on lighting red alarm LEDs; the cursor position is indicated by a fastly flashing "Alarm" LED. Then the numerical 7-segment display shows the highest priority active and yet unacknowledged alarm associated with that LED, e.g. "AL.20" excessive harmonics with the red "Alarm" LED "THDU". On acknowledging that alarm using the "SET" key the possibly also active alarm "AL.21" excessive THDU of less priority will show through.

Is any of the acknowledged and no more presented alarms still active the numerical 7-segment display shows at times "**AL...**" as indication. Use menu item "**CO. 8**" within the menu tree "Set" for restoration of all still active alarms.

The alarm groups Temperature and Software are not represented by an "Alarm" LED within the left sided vertical LED menu ribbon. Therefore the highest priority active alarm of those alarm groups is at times directly displayed in the numerical display. It can be acknowledged by the "SET" key when the menu cursor is positioned in the [Standard Screen](#) (see page [27](#)) at "Auto" / "cos phi".

Software errors, are reported as alarm ("AL.29"/"eeee"/"xxxx") for max. 15 min. after the reset they have triggered. Please record the decimal error number eeee and its hexadecimal supplement xxxx. If the same SW error is again detected inform the controller manufacturer reporting both numbers. You may terminate the SW error presentation prior to the 15 minutes by proceeding the menu cursor a whole turn around using the "↓" key.

## 4 Operations

The "Auto" menu comprising the items assigned to green LEDs within the left sided vertical LED menu ribbon is desired for use by the customer as well as for the service staff. Moreover the service staff may use the whole menu including the menu trees "Info" for readings (see chapter [4.3 Information Retrieval \(Menu Tree "Info"\)](#), page [28](#)), "Set" for settings and actions (see chapter [4.4 Programming \(Menu Tree "Set"\)](#), page [29](#)), and acknowledge alarms (see chapter [3.5 Alarms](#), page [21](#)). Use the [Keyboard](#) for menu navigation.

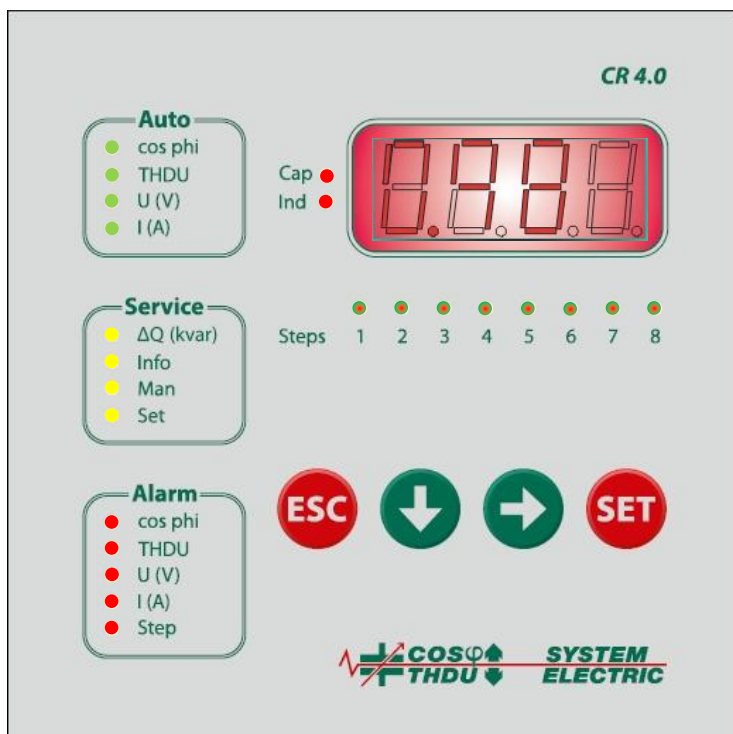

Figure 3 Front Panel of the Reactive Power Controller CR4.0

### 4.1 Controls

The display of the Reactive Power Controller CR4.0 comprises a 4-digit numerical 7-segment display and several singular light emitting diodes (LEDs) organized as a left sided vertical and a horizontal ribbon. Passing reset all LEDs and segments of the numerical display light about 2 seconds for lamp test.

### 4.1.1 LED Menu Ribbons

The front panel of the Reactive Power Controller CR4.0 comprises two indication and menu ribbons composed each from chained singular LEDs.

The **Left Sided Vertical Menu Ribbon** founds the huge complex menu structure with several menu trees. The menu ribbon departs in 3 regions: "Auto" with green LEDs, "Service" with yellow LEDs, and "Alarm" with red LEDs.

- Any green "**Auto**" LED indicates how to interpret the reading shown in the numerical 7-segment display. The unexperienced customer should not try to understand nor to change any item below the green "Auto" region.

During automatic regulation mode without error only the green "Auto" / "cos phi" LED lights indicating regular operation while the numerical display shows the actual cos phi in the (HV) mains network.

A green "Auto" LED may additionally light or blink during result presentation of automatic commissioning or during navigation through the menu trees when the respective value is shown in the numerical display.

- The region of the yellow "**Service**" LEDs is intended for use by experienced service staff. The "Service" LEDs allow to read the missing reactive power necessary to reach the target cos phi " $\Delta Q$ ", for entry into the deep menu trees "Info" or "Set", or for entry into the manual mode "Man".

The yellow "Man" LED is blinking as long as the controller operates in manual mode. It flashes very fast for a few seconds if entry into the manual mode's action menu is forbidden.

One of the yellow "Info" / "Set" LEDs is blinking when the menu cursor resides in the respective menu tree.

- The respective red "**Alarm**" LEDs indicate extraordinary situations or errors of the named kind that should be noticed by the customer or the service staff and that potentially requires intervention or repair.

According to the severeness (note: the red "Alarm" LEDs only light but do not blink) all steps of the capacitor bank may be affected by an alarm switch-off or single steps may be out of operation due to resonance or defect.

- Rote "**Alarm**"-LEDs leuchten bei Vorliegen einer außerplanmäßigen Sachlage, die dem Endnutzer oder Service-Personal zu Kenntnis gebracht wird und ggfs. einen Eingriff zur Behebung erfordert.

The cursor position within the left sided vertical menu ribbon proceeds circularly by the arrow down key "↓". The "ESC" key returns to the [Standard Screen](#) (see page [27](#)).

The **Horizontal "Steps" LED Ribbon** is used for indication of steps states and steps in error. It comprises 8 LED positions named "1" to "8" compliant with steps numbering. Every position is equipped with a 2-color LED green and red.

Regardless of the indication provided by the red LED the green LED indicates the state of the respective step: on=lighting, off=dark.

The red LED is multifunctional: it permanently lights if that step is off and out of service, it slowly blinks (frequency about 1,25Hz) if that step is in error but still operational, e.g. after passing over the cycles threshold, and it fastly lashes (blink frequency about 2,5Hz) when it is selected by the steps cursor within a step related menu item. The red "Steps" LED flashes very fast (blink frequency about 5Hz) for a few seconds if in manual mode the command to switch that step on had been refused.

#### 4.1.2 Numerical 7-Segment Display

Numbers and short text messages are displayed by the 4-digits **Numerical 7-Segment Display** in the upper right of the front panel. The decimal point separates numbers into their integer part and the decimal places. Where appropriate the two LEDs "Cap" and "Ind" form a quasi sign for numbers that may characterize e.g. a capacitive resp. inductive reactive power. When a minus sign is needed the number must not exceed 3 digits.

Due to open a number for input use the "SET" key. The digit where the numerical cursor stands is blinking. That may also be the "Cap" or "Ind" LED if a selection is allowed. Use the arrow down key "↓" to decrease the digit at the cursor position or toggle between "Cap" and "Ind". From the 0 decreasing wraps to 9 (or the highest figure allowed at that position which may be "F" for hexadecimal). Use the arrow right key "→" to proceed right to the next digit. Striking "→" at the rightmost digit or the "SET" key at any cursor position enters the new value. That value is checked and if it is outside the allowed range the controller reverts to the former value as it does on striking the "ESC" key at any cursor position.

Some menu items do not allow to input a number but after opening with the "SET" key offer a ribbon of selectable values with the numerical cursor blinking at the rightmost digit. Use the arrow down key "↓" for selection and "SET" or "ESC" for accept or revoke.

The whole number blinks, if something is wrong with that number, e.g. the reading for actual current blinks if the current transducer had not been entered.

When the menu cursor resides in one of the menu trees "Info" or "Set" the actual menu item address is displayed as alphanumeric text like "H3. 5". That



is composed from the group identifier, here "H" for harmonics readings, the readings / parameter series, here "3" for maximum values of voltage harmonics, and from the numbered reading category / parameter number, here "5" for the 5<sup>th</sup> harmonic component. In general numbering begins with 1 but in particular harmonic components count from 0 standing for the THD and 1 for the fundamental. In the steps menu group "Set" / "S" number 0 stands for programming all steps to the same value and is so displayed, e.g. "St.All".

The pure text fragments are self-explanatory or borrowed from english language. A complete list of text fragments is given in the appendix, see [6.3.2 Characters and Texts at the Numerical 7-Segment Display](#) on page [75](#).

### 4.1.3 Keyboard

The Reactive Power Controller CR4.0 comprises 4 membrane keys with mechanical click.

- **"ESC"** (Escape) aborts an input or an action or returns the menu cursor to the former hierarchical level within the menu trees. It terminates the manual mode if entered at the manual mode standard screen ("Man" cursor position).
- **"↓", "→" (arrow keys)** move the cursor within a menu ribbon or within the menu trees into the direction shown to the next menu item. In general no cursor movement if not applicable e.g. arrow right inside the vertical LED ribbon; but note that the exceptions prove the rule, refer to the particular descriptions of special menu items. Sometimes the orthogonal arrow key works in the same manner as the "SET" key, e.g. enter the "Info" menu tree from the left sided vertical LED menu ribbon by "SET" or alternatively by the arrow right key "→".

The standard pathes to a menu item through the menu trees are designed for alternating use of both directions. Within 2-dimensional menu matrixes both directions can be useful at the same time, e.g. within the readings matrix the arrow down key "↓" proceeds to the next reading series holding the category while the arrow right "→" proceeds to the next reading category holding the series.

All menus have been designed such that selecting a step by the step cursor always uses the natural arrow right key "→". Note that with other menu ribbons at wrap around between the last position "8" and the "1" there exists an intermediate position where all or no "Steps" LEDs are selected. That position is used either for ".All" selection when an input value affects all steps or for escape into the higher menu level, e.g. to temporarily leave the manual mode action menu.

Within a selection ribbon the arrow down key "↓" selects the next entry. Within number input the arrow down key "↓" decrements the digits where the

numerical cursor resides (wrap around from 0 to 9 resp. the highest allowed number for that digit). The arrow right key "→" proceeds to the next less order digit; from the rightmost digit arrow right acts like the "SET" key as the enter-command.

- **"SET"** starts an action or within the menu trees forces entry into the next lower menu level. "SET" opens number input / item selection or closes them.

Keys striked about 3 seconds at the same time issue a special function:

- "ESC" and "SET" (**both red keys**): **Emergency Stop**; the controller is turned out of operation, operational mode SHUTDOWN ("StoP").
- "↓" und "→" (**both green keys**): **Reset**, restart after emergency stop.

Note: Because the arrow keys lie very close together service staff with thick fingers has to use one finger each of both hands.

#### 4.1.4 Number entry, item selection

The 4-digits red 7-segment display presents settings and numbers in several display formats. If necessary the "Cap" and "Ind" LEDs act as sign indicator in the reactive power system, or a "+" and a "-" sign in the leftmost digit form a general sign indicator. Bit pattern are shown as hexadecimal number using the figures "0" .. "9", "A", "b", "C", "d", "E", and "F". The decimal point separates the integer part and the decimal places. Values that do not represent a number in terms of a measurability have the decimal point suppressed.

When a menu item representing a number has been opened, its actual content is shown usually alternating with the menu items address. Open the input mode using the "SET" key. If the content shown is a number preceding zeros will be applied. Some menu items suggest a frequently used number as input default if that item had never been entered yet, e.g. 50kvar for steps powers. The leftmost digit that may be input is blinking, that may also be the "Cap" / "Ind" LEDs if altering is allowed.

If desired change the blinking digit with the arrow down key "↓". Number figures are decremented on every keystroke. From the lowest figure at that digit, usually "0", the figure wraps to its highest value, usually "9" for decimal numbers resp. "F" for bit patterns in hexadecimal.

When the blinking digit shows the desired figure then use the arrow right key "→" to proceed to the next digit at the right. With the arrow right key at the rightmost digit or with the "SET" key anywhere you finish input mode and present your input to the controller. On acceptance the inputted number replaces its former value. Don't become confused when the accepted number does not exactly match your input. Some values are hold inside the controller in terms of an intrinsic scale, e.g. steps powers. Your input ist rounded to the next

available number, e.g. if you entered a step power of 50.0kvar one controller may internally convert it to 49.8kvar, another one to 50.3kvar as rated by calibration of components tolerances.

The controller rejects improper input leaving the old contents unchanged. The same happens when aborting the input with the "ESC" key. Also return to the [Standard Screen](#) (see page [27](#)) after 3 minutes without keystroke aborts input.

Due to speed up the lengthy input procedure the invalid figures for the particular digit will be skipped. E.g. at cos phi input the figure "1" directly follows the figure "0" at the integer digit on pressing the arrow down key "↓", and because the cos phi must not exceed 1.00 both decimal digits jump to "00"; changing the integer digit from "1" to "0" causes the decimal digits to jump to "99" because it usually takes less keystrokes to reach the desired value from there.

Pairs of parameters, e.g.. "In. 4", current transducer primary / secondary, can be changed only as a pair, i.e. both parts have to be accepted. When the whole number is blinking an improper or incomplete item is shown, e.g. all current and power readings are blinking before for the first time a current transducer has been input; in that case all values are shown with respect to 5A / 1A current sense using 2 decimal digits.

After opening input with "SET" for a selection list only the rightmost digit is blinking. You can cyclically browse through-out the input list with the arrow down key. Use "SET" to accept your choice or "ESC" to abort selection. Return to the [Standard Screen](#) (see page [27](#)) after 3 minutes without keystroke aborts input.

## 4.2 Standard Screen

The Reactive Power Controller CR4.0 returns to the **Standard Screen** after 3 minutes of no activity (keystroke, active long-term action, or result presentation). Pending input, menu navigation, etc. is aborted.

For the operational modes Automatic Regulation "Auto" and Out of Operation "StoP" (SHUTDOWN) the menu cursor resides at the green LED "Auto" / "cos phi" and the numerical display shows the actual cos phi; note that the green LED itself may stay off as long as the automatic regulation is shut down or is blocked due to alarm switch-off. For manual mode standard screen lets the menu cursor reside at the yellow "Man" LED in the left sided menu ribbon while showing "MAN" at the numerical display.

In the Commissioning Mode the menu cursor resides at the green "Auto" / "U (V)" LED of the left sided vertical menu ribbon because both menu LEDs above are locked out (in general the cos phi cannot be evaluated before the commissioning process has determined the mains net configuration).

### 4.3 Information Retrieval (Menu Tree "Info")

From the Menu Tree "Info" you can get information on readings and other values monitored by the controller. No changes of values or settings are possible. Use the arrow keys to navigate through the menu tree "Info".

Use the arrow right key "→" to proceed the menu cursor for selection of one of the menu groups provided by the first hierarchical menu level of "Info":

"C1 " Basic information according to the code table, see chapter [5.3.1](#)

"M " Measurement values with actual readings and their min/max, see [5.3.2](#)

"H " Harmonics with actual readings and their maximum, see chapter [5.3.3](#)

"S " Step related values for the capacitor bank, see chapter [5.3.4](#)

"A " Alarms counts, see chapter [5.3.5](#)

during that the yellow "Service" / "Info" LED blinks due to indicate that the menu cursor resides with the "Info" menu tree.

Subsequently because of the alternating use of arrow directions for the next hierarchy level the arrow down key "↓" (or "SET") enters the menu group where the menu cursor resides. Also use the arrow down key for proceeding the menu cursor within that menu group to select either a menu item of the 1-dimensional basic information group or to select a menu series from the other 2-dimensional menu matrixes, e.g. "M1. 6"=actual reading, "M2. 7"=maximums of the actual readings, etc.

Afterwards select in the third hierarchy level of the menu matrixes the desired menu item, proceeding the menu cursor with the arrow right key "→", e.g. in the measuring values matrix "M1. 6"=actual real power, "M1. 7"=actual reactive power, etc. The "Info" groups H, S, and A use natural numbering, e.g. "H1.13"=the actual share of voltage harmonics from the 13<sup>th</sup> harmonics, "S4. 6"=number of cycles on/off for step 6 of the capacitor bank, "A2.21"=count of THDU alarms ever appeared, etc.

Use the arrow down key to navigate the menu cursor within the basic information group or both arrow key for navigation inside the 2-dimensional menu matrixes. Note that besides the third hierarchy level after wrap around from the last cursor position to the first one there is always an intermediate state where the cursor stands in the menu ribbon of the next higher hierarchy level. Thus you may navigate to the deepest menu item and back again only using the arrow keys. But feel encouraged to enter / leave hierarchy levels by "SET" and "ESC" if that is more compliant to you.

The "ESC" key forces the menu cursor to return to the next upper hierarchy level, in general to that point from where you have entered the lower hierarchy level but sometimes it is only possible to return to the first menu item of the upper level. Thus with a maximum of 5 "ESC" you can abort any input or action and return to the [Standard Screen](#) (see page [27](#)).

## 4.4 Programming (Menu Tree "Set")

The **Menu Tree "Set"** provides configuration management as well as special actions access. Use the arrow keys to navigate through the menu tree "Set".

Use the arrow right key "→" to proceed the menu cursor for selection of one of the menu groups provided by the first hierarchical menu level of "Set":

"C0 " Basic settings and actions according to a code Table, see chapter [5.4.3](#)

"In " Settings and actions for initiation / commissioning, see chapter [5.4.4](#)

"S " Steps related settings and values, see chapter [5.4.5](#)

"P " Parameter settings and configurations, see chapter [5.4.6](#)

during that the yellow "Service" / "Set" LED blinks due to indicate that the menu cursor resides with the "Set" menu tree.

Subsequently because of the alternating use of arrow directions for the next hierarchy level the arrow down key "↓" (or "SET") enters the menu group where the menu cursor resides. Also use the arrow down key for proceeding the menu cursor within that menu group to select either a menu item of the 1-dimensional basic setting or the initiation groups or to select a menu series from the other 2-dimensional menu matrixes, e.g. "St " =Step type, "S0 " =Initial steps powers, etc.

Afterwards select in the third hierarchy level of the menu matrixes the desired menu item, proceeding the menu cursor with the arrow right key "→". The 2-dimensional "Set" groups S, and P use natural numbering, e.g. "Sc. 6" =number of cycles on/off for step 6 of the capacitor bank, "P0.21" =21th parameter from the parameter list, etc. Note: the lists of configurable parameters can vary with the Software Version; if you can't match the settings in the controller with this manual please look at the short form "Menu Structure" paper shipped with each Reactive Power Controller CR4.0 or visit the manufacturer's internet pages.

Use the arrow down key to navigate the menu cursor within the 1-dimensional basic setting or the initiation groups or both arrow key for navigation inside the 2-dimensional menu matrixes. Note that besides the third hierarchy level after wrap around from the last cursor position to the first one there is always an intermediate state where the cursor stands in the menu ribbon of the next higher hierarchy level. Thus you may navigate to the deepest menu item and back again only using the arrow keys. But feel encouraged to enter / leave hierarchy levels by "SET" and "ESC" if that is more compliant to you.

The "ESC" key forces the menu cursor to return to the next upper hierarchy level, in general to that point from where you have entered the lower hierarchy level but sometimes it is only possible to return to the first menu item of the upper level. Thus with a maximum of 5 "ESC" you can abort any input or action and return to the [Standard Screen](#) (see page [27](#)).

When the service password has been set almost every setting or action within the menu tree "Set" is password protected. Despite that you can see most of the

protected settings but before changing you must enter the password. Note that a few settings or actions require a special password and should only be changed by service staff authorized by SYSTEM ELECTRIC Power Quality GmbH. Also note that some menu items are not available in improper controller variants or are not visible until the special password has been entered.

## 5 Detailed View

### 5.1 Technical Data

#### Measuring System

Type of measuring system single phase, electronic

<u>Measuring Voltage</u>	58V..700V AC {-100V variant 50V..250V AC}, maxx, 780V AC
Resolution	raw approx. 1,0V {0,4V}; filtered approx.0,2V {0,1V}
Accuracy	repeat accuracy approx. 0,6%; abs. approx. 1,5%
Input impedance	high impedance, <50μA
Fusing	max. 4A
Harmonics	Fourier analysis, filtered 1. .. 31. harmonics
<u>Measuring Current</u>	0 .. 5A AC, max. 7.7A (-1A variant 0 .. 1A AC, max. 2A)
Resolution	raw approx. 10mA {2mA}; filtered approx. 3mA {1mA}
Accuracy	repeat accuracy approx. 0,6%; abs. approx. 1,5%
Input impedance	0,3VA q 5A =12mΩ (90mVA @ 1A =90mΩ)
Harmonics	Fourier analysis, filtered 1. .. 31. harmonics

Regulation bases on the filtered measuring readings (-8K) resp. on the raw measuring values (-8T, -4T4K)

Frequency Range	45Hz .. 65Hz (lock-in range); 41Hz .. 69Hz (pull-in r.)
Temperature Measur.	about -20°C ... +70°C

#### Power Supply

Supply Voltage	230V AC, 50/60Hz
Power consumption	<15VA
Fusing	max. 4A
Ambient Temperature	-10°C .. +60°C

#### Steps Outputs

Number of Outputs / Output Types	8, Relays for contactors (-8K) or Transistors for thyristor switches (-8T), in variant -4T4K mixed
<u>Relay Output</u>	for contactors: 250V AC, max. 4A, in total max. 4A
Fusing	max. 4A
<u>Transistor Output</u>	for thyristor switches 10V DC, max. 150mA (single / Σ)
external power supply	(variants -E) 8..16V DC (abs.max. 20V), Σ max. 1.2A
<u>Alarms / Fan relay</u>	250V AC, max.4A
Fusing	max.4A

#### Panel Mounting

Case	Panel-mounting case 144mm x 144mm acc. DIN IEC 61554 approx.
Panel Opening	138mm x 138mm
Case Depth	60mm

## 5.2 LED Ribbons in Detail

The front panel of the Reactive Power Controller CR4.0 comprises two indication and menu ribbons composed each from chained singular LEDs.

### 5.2.1 Left sided, Vertical LED Ribbon

The Left sided Vertical LED Ribbon consists of three LED groups "Auto" with green LEDs, "Service" with yellow LEDs, and "Alarm" with red LEDs.

Any LED is selected by proceeding the menu cursor from top to bottom with wrap around using the arrow down key "↓". The red "Alarm" LEDs can be selected only if they are lighting or blinking. The just selected LED is lighting resp. fastly flashing (2.5Hz). Blinking LEDs (1.25Hz) have a special meaning specified below.

#### 5.2.1.1 Green "Auto" LEDs and yellow "Service" LED "ΔQc": Direct Presentation of a Measured Value

The following readings of actual measured categories can be displayed:

- "cos phi" The actual cos phi at fundamental frequency in the mains network using the "Cap"/"Ind" LEDs als sign; presentation with 2 decimal places; " -.-" for invalid cos phi
- "THDU" The actual harmonic total distortion of the voltage with shares from the 2<sup>nd</sup> to the 31<sup>th</sup> harmonics in percent with 1 decimal place; " -.-" for invalid measuring
- "U (V)" The actual measured voltage; RMS value with all harmonics in volts
- "I (A)" The actual measured current; RMS value with all harmonics in ampere; prior to specifying the current transducer ratio blinking presentation with 2 decimal places based on the 5A/1A raw input
- "ΔQc" Reactive power missing to reach the target cos phi in kvar using the "Cap"/"Ind" LEDs as sign; prior to specifying the current transducer ratio blinking presentation with 2 decimal places based on the 5A/1A raw input

The green LEDs allow direct input for one parameter each:

- "cos phi" The target cos phi with the "Cap"/"Ind" LEDs as sign: 1.00 [ind 0.70 .. cap 0.80] (tariff 1 resp. actual tariff with PI. 1=tariff change 1/2)
- "THDU" The alarm threshold for THDU exceedance: according to the detuning factor 3.0%, 7.0%, 9.0% [0; 2.0% .. 45.0%]
- "U (V)" Commissioning: The voltage transducer ratio: 1 [1 .. 9999]  
Normal Operation: Alarm threshold Undervoltage in percent with respect to the nominal voltage  $U_{\text{mains}}$ : 88 [85 .. 95]
- "I (A)" Commissioning: The current transducer ratio: 1 [1 .. 9999] <100>  
Normal Operation: Alarm delay long / Dead Time on Inrush in seconds: 5.00 [0.00 .. 20.00]



Use the "→" key to toggle between actual reading and parameter setting, indicated by the LED is blinking. Open parameter for input by "SET" and accept changes by "SET" or abort input by "ESC". Return to actual reading by "→" or "ESC". Parameter setting may be password protected, refer to chp. [5.4.1](#) on page [40](#).

A legend for the defaults and input ranges is given in chapter [5.4.2](#), on page [40](#).

### 5.2.1.2 Yellow "Service" LEDs: Action LEDs

In general the readings and actions associated with the yellow "Service" LEDs will overstrain the customer. Those items are intended for use by the service staff due to have detailed informations on mains and the regulation, due to optimize the controller, and for special purposes, eg. repair.

The menu cursor resides (deep) inside either menu tree "Info" or "Set" when the respective yellow "Service" LED is blinking. In contrast a static lighting LED together with "InFo" or "SEt" shown at the numerical display indicates that the menu cursor stands at that point within the left sided vertical LED menu ribbon and may proceed to the next LED by striking the arrow down key "↓".

When the yellow "Service" LED "Man" is blinking the controller has stopped automatic regulation and the manual mode is active, see [3.2 Manual Mode](#), page [17](#). If the numerical display shows "MAN" the menu cursor still stands in the left sided vertical LED menu ribbon while. Strike "SET" or arrow right "→" to enter the manual mode action menu (the selected "Steps" LED "1" fastly flashes) or proceed to the "Set" LED below using the arrow down key "↓".

### 5.2.1.3 Red "Alarm"-LEDs: Alarms

Five (of seven) alarm groups are associated with one of the red "Alarm" LEDs. Any alarm type forces the respective LED lighting when the alarm is new (=active and not acknowledged). When the menu cursor is placed on a lighting red "Alarm" LED the highest priority new alarm of that group ist shown as e.g. "AL.12" at the numerical display. From two other alarm groups without LED the highest priority alarm is directly shown at the numerical display.

The read "Alarm" LEDs always light permanently due to avoid irritation of the user. Thus to differ alarms with alarm switch-off of all steps from alarms without any switch-off or with single step switch.off look at the numerical display: alarm switch-off is indicated by "-AL-" displayed at times.

Important alarms that should be noted by the customer or by the service staff (e.g. overvoltage) remain alarmed even though the alarm reason has vanished until that alarm has been acknowledged.

For acknowledge proceed the menu cursor within the left sided vertical LED menu ribbon onto the red lighting "Alarm" LED; the numerical display shows the highest priority new alarm associated to that LED (e.g. "AL.17" voltage above the

measuring range). Strike "SET" to acknowledge that alarm. If still present the acknowledged alarm is held in the background indicated at times by "AL..." at the numerical display but is vanished if already inactive. After acknowledging a possibly also new lower priority alarm for that LED will come through (e.g. "AL.12" overvoltage). Restore already acknowledged alarms from the background using menu item "C0. 8".

Not LED associated alarms may be acknowledged striking "SET" with the menu cursor standing at the green "Auto" / "cos phi" LED. Any Software error ("AL.29") is shown only for a quarter hour after the reset that it had triggered; during that period you may suppress its presentation by proceeding the menu cursor one loop around the left sided vertical LED menu ribbon.

The assignment of alarm types to the alarm groups / LEDs and their priority is specified in [Table 4 Alarm Types](#), page [60](#).

## 5.2.2 Horizontal "Steps" LED Ribbon, green and red

The **Horizontal "Steps" LED Ribbon** is used for indication of steps states and steps in error. It comprises 8 LED positions named "1" to "8" compliant with steps numbering. Every position is equipped with a 2-color LED green and red that are lighting exclusively avoiding mixed colour.

Regardless of the indication provided by the red LED the green LED indicates the state of the respective step: on=lighting, off=dark.

The red LED is multifunctional: it permanently lights if that step is off and out of service, it slowly blinks (frequency about 1,25Hz) if that step is in error but still operational, e.g. after passing over the the cycles threshold, or if it is tested by the controller. It fastly flashes (blink frequency about 2,5Hz) when it is selected by the steps cursor within a step related menu item. For a few seconds the red "Steps" LED at the steps cursor flashes very fast (blink frequency about 5Hz) if a command related to that step had been refused, e.g. in manual mode switch that step on during idle time.

## 5.3 Menu Tree "Info" in Detail

### 5.3.1 Basic "Info" Group acc. Code Table ("C1. ")

The 1-dimensional Basic Information Group according the Code Table "Info" / "C1. " offers non-reading data and readings that would be missing in the planned Basic Variant without the large menu trees. Proceed to the next menu item using the arrow down key "↓".

The following menu items are defined:

- C1. 1 Actual reading I1P; real part of the fundamental's current (= "M1. 4")
- C1. 2 Actual reading I1Q; reactive part of the fund.'s current (= "M1. 5")  
 Currents In A without decimal places; prior to specifying the current transducer ratio blinking presentation with 2 decimal places based on the 5A/1A raw input. With I1Q the "Cap"/"Ind" LEDs are used as sign (phase indicator)
- C1. 3 Actual reading THDI; total harmonic distortion in current up to 31<sup>th</sup> harmonics in percent with 1 decimal place (= "H2. 0")
- C1. 4 Actual effective compensation power Qon. The sum of steps powers switched on in the capacitor bank calculated to the actual voltage and frequency In kvar without decimal place (= "M1. 8"); prior to specifying the current transducer ratio blinking presentation with 2 decimal places based on the 5A/1A raw input.
- C1. 5 shows a chain of settings and values that have been rated during commissioning, i.e. the net configuration and the steps powers. The presentation itself proceeds to the next item every 2 seconds; additionally you can force proceeding using the arrow right key "→".  
 e.g. "180°/" 400. "/" 240" /" 200. "/" 24. "/" 26. "/" 50. "/" 49. "/" 51. "/" -" /" -" /" -"  
 denotes phase angle = 180° (=e.g. N-L1; L1 k-l); nominal mains voltage = 400V; current transducer ratio 240 (e.g. 1200.5); total power of the capacitor bank = 200kvar consisting of 2 steps of about 25kvar and 3 steps of about 50kvar with all "Steps" LEDs flashing during total power resp. the single LED assigned to that step.
- C1. 6 Steps powers losses per step since commissioning, at first for step 1, proceed to the next step with "→". The arrow down key "↓" proceeds to C1. 7 from any step number. Readings in percent with one decimal place. (= "S1.yy")
- C1. 7 shows a chain of actually measured raw readings valid at the connector strip. The presentation itself proceeds to the next item every 2 seconds; additionally you can force proceeding using the arrow right key "→".  
 e.g. " 226. "/" " 1.91"/" 50.08" denotes an actually measured voltage of 226V; current of 1.91A basing on 5A/1A; frequency about 50.08Hz at measuring voltage.  
 Note: For lack of an accurate crystal oscillator the frequency can only be measured in a broad granularity of about 0.15Hz at an absolute accuracy of about 0.3Hz and therefore is normally shown with no decimal place only. Due to monitor the tendence of fluctuations as an exception the frequency is given here with 2 decimal places.
- C1. 8 Software version number, 4-digit with leading zeros (e.g. "01.02")
- C1. 9 Hardware serial number per device, 4 digit with leading zeros (e.g. "0948")
- C1.10 Controller variant -4T4K ("4t4h"), -8T (" 8t"); this menu item in total is skipped at the -8K controller standard variant

It seems as if some items of this menu group are needless because they are the same as other menu items. Note that the planned Basic variant of the Reactive Power Controller CR4.0 does not include the large, sophisticated 2-dimensional menu groups of the "Info" and "Set" menu trees.

### 5.3.2 "Info" Menu Group Measurement ("M . ")

Any menu item "Mx.yy" of the **Measurement Menu Group** shows the particular reading from the measurement series x for the measurement category yy, e.g. "M4. 7" the latest value of real power averaged during a quarter hour (hence this reading may be 0 ... 1/4h old).

The following measurement series are defined:

- M1.yy **Actual reading**, Momentary value (meas. period 0,3s at standard)
- M2.yy Maximum of momentary values (peak value)
- M3.yy Minimum of momentary values (peak value)  
Min/max values are gathered during normal operation only, not during commissioning.
- M4.yy Actual quarterly reading (Meas. period 1/4h, unsynchronized)
- M5.yy Maximum of quarterly readings
- M6.yy Minimum of quarterly readings

The min/max values have been gathered since the last min/max reset (menu item "C0.11")

The following measurement categories can be displayed:

- Mx. 1 IRMS RMS value of the total current (including harmonics)
- Mx. 2 I1S Apparent current at fundamental frequency
- Mx. 3 I1P Real current at fundamental frequency
- Mx. 4 I1Q Reactive current at fundamental frequency  
Currents in A without decimal place; prior to specifying the current transducer ratio blinking presentation with 2 decimal places based on the 5A/1A raw input. With I1Q the "Cap"/"Ind" LEDs are used as sign
- Mx. 5 URMS RMS value of the total voltage (including harmonics)
- Mx. 6 P1 Fundamentals part of the real power in kW (supply; neg. values for generator delivery)
- Mx. 7 Q1 Fundamentals part of the reactive power in kvar (when basic load / fixed compensation power in use then for the low voltage mains NV; add the fixed compensation power for virtual reading at HV); the "Cap"/"Ind" LEDs are used as sign  
Prior to specifying the current transducer ratio P1, Q1, Q1miss blinking presentation with 2 decimal places based on the 5A/1A raw input.
- Mx. 8 Qon Compensation power effective in mains network in kvar with 1 or no decimal place(s); the nominal steps powers become computed to the actual voltage and frequency.
- Mx. 9 Q1miss Compensation power missing to reach the target cos phi in kvar without decimal place
- Mx.10 cos phi [,B] Power factor HV (with fixed comp. power at medium voltage)
- Mx.11 cos phi [,T] Power factor NV (with fixed comp. power at low voltage)
- Mx.12 Temperature in °C (the daily mean is shown instead of the quarterly readings)
- Mx.13 Frequency in Hz without decimal place (limited accuracy !)

**Matrix of Measured Values including their Units at display**

Meas.Series x / Meas.Category yy	1: $I_{RMS}^{6)}$	2: $I_{1S}$	3: $I_{1P}$	4: $I_{1Q}$	5: $U_{RMS}^{6)}$	6: $P_1$	7: $Q_1$ [,T] <sup>4)</sup>
Category Unit	A <sup>1)</sup>	A <sup>1)</sup>	A <sup>1)</sup>	A <sup>1)</sup>	V	kW <sup>1)</sup>	kvar <sup>1)</sup>
1: Actually Measured Value	✓	✓	✓	✓	✓	✓	✓
2: Maximum of 1	✓	✓	✓	✓	✓	✓	✓
3: Minimum of 1	✓	✓	✓	✓	✓	✓	✓
4: Actual 1/4h-Value	✓	✓	✓	✓	✓	✓	✓
5: 1/4h-Maximum of 4	✓	✓	✓	✓	✓	✓	✓
6: 1/4h-Minimum of 4	✓	✓	✓	✓	✓	✓	✓

Meas.Series x / Meas.Category yy	8: $Q_{on}^{2)3)}$	9: $Q_{1miss}^{3)}$	10: $\cos \phi$ [,B] <sup>3)4)</sup>	11: $\cos \phi$ [,T] <sup>3)4)</sup>	12: $\partial$ Tem- perature	13: f Fre- quency
Category Unit	kvar	kvar <sup>1)</sup>			°C	Hz
1: Actually Measured Value	✓	✓	✓	✓	✓	✓
2: Maximum of 1	✓ (ind)	✓ (ind)	✓ (ind)	✓ (ind)	✓	✓
3: Minimum of 1	✓ (cap)	✓ (cap)	✓ (cap)	✓ (cap)	✓	✓
4: Actual 1/4h-Value	✓	✓	✓	✓	daily	✓
5: 1/4h-Maximum of 4	✓ (ind)	✓ (ind)	✓ (ind)	✓ (ind)	mean	✓
6: 1/4h-Minimum of 4	✓ (cap)	✓ (cap)	✓ (cap)	✓ (cap)	value <sup>5)</sup>	✓

Table 2 Measurement Values of the "Info" Group "M . . "

Remarks:

- 1) Befor specifying current transducer ratio like 5A:5A=1 with 2 decimal places basing on the raw 5A/1A measuring current
- 2) Qon computed for actual voltage / frequency
- 3) This are signed categories: negative values stand for capacitive, positive values for inductive. Maximum numerical value is the most inductive value and minimum numerical value is the most capacitive value. If all numerical values originate from only one quadrant maximum and minimum may have the same sign visualized by only one the "Cap"/"Ind" LEDs.
- 4) [,T]: with fixed comp. power: at Transducer in the low voltage mains (NV)  
[,B]: with fixed comp. power: Basic load corrected in medium voltage (HV)
- 5) The daily mean is shown instead of the quarterly mean value
- 6)  $I_{RMS}$  and  $U_{RMS}$  include all harmonics
- 1 Index 1 denotes catagories filtered for the fundamental frequency only

### 5.3.3 "Info" Menu Group Harmonics ("H . ")

Any menu item "Hx.yy" of the **Harmonics Menu Group** shows the particular reading from the measurement series x for yy<sup>th</sup> harmonics component, e.g. "H4. 7" the maximum value for the 7<sup>th</sup> component of current harmonics.

The following measurement series are defined:

- H1.yy Actual measured reading of the yy<sup>th</sup> component of **Voltege Harmonics** (measuring period about 2.5s at standard)
- H2.yy Actual measured reading of the yy<sup>th</sup> component of **Current Harmonics** (measuring period about 2.5s at standard)
- H3.yy Maximum of the yy<sup>th</sup> component of Voltege Harmonics
- H4.yy Maximum of the yy<sup>th</sup> component of Current Harmonics
- H5.yy Actual measured of the yy<sup>th</sup> component of **Voltege Harmonics** (unsynchronized **quarterly mean** of the actual readings)
- H6.yy Actual measured of the yy<sup>th</sup> component of **Current Harmonics** (unsynchronized **quarterly mean** of the actual readings)
- H7.yy Maximum of the yy<sup>th</sup> component of quarterly meaned Voltege Harmonics
- H8.yy Maximum of the yy<sup>th</sup> component of quarterly meaned Current Harmonics

The min/max values have been gathered since the last min/max reset (menu item "C0.12")

Harmonics are monitored up to the 31<sup>th</sup> harmonic component. As an exception component numbering begins not with 1 but with zero. Harmonics no. 0 is the total harmonic distortion THD; thus "H1. 0" is identical with the "THDU" at the green "Auto"-LED. Harmonics no. 1 is the fundamental; it is always near 100% and thus internally stored as (100% -value); so its maximum value is the more informative minimum of the fundamental.

### 5.3.4 "Info" Menu Group Steps ("S . ")

Any menu item "Sx.yy" of the **"Info" Menu Group Steps** shows the particular reading from the information series x for step yy, e.g. "S4. 7" the cycles on / off of step 7 within the capacitor bank.

The following measurement series are defined:

- S1.yy Derating of steps powers in percent as related to the initial power stored during commissioning. Momentary fluctuations in voltage and frequency have been computed off.  
Any power grow-up caused e.g. by a transducer overload during commissioning is not shown (CR2020: negative percentages).
- S2.yy Latest steps powers measured during normal operation or repair/test
- S3.yy Initial steps powers stored at commissioning. Reference for derating.

Steps powers in kvar with 1 resp. no decimal place(s). The number of decimal places is controlled by the maximum system size that can be handled by the Reactive Power Controller CR4.0, e.g. at 400V/231V L-N change of decimal places is between current transducers 500A:5A and 600A:5A, at 400V/400V L-L between 250A:5A and 333A:5A. Prior to specifying the current transducer ratio blinking presentation with 2 decimal places based on the 5A/1A raw input.

If not a plain capacitor bank is configured the "Cap"/"Ind" LEDs are used as sign for capacitive capacitor steps or inductive reactor steps.

Note that powers of a single step greater than 999.9 kvar can not be entered by hand; the only way to get those big steps sizes is to gauge them with standard commissioning without pre-programming.

Note: At standard the Reactive Power Controller CR4.0 uses for regulation the latest step power measured during normal operation if available; otherwise or with defect analysis / steps powers measurement turned off ("C0. 7" / "Pb. 2" == " On") the controller uses the initial steps powers.

S4.yy Detuning factor in percent with 2 decimal places; may be individual per step due to obtain a kombi-detuned or absorption-circuit system ("Pb. 9" == " On"/" OFF"). Note that a difference in detuning factors to any digit activates that special type of regulation with confusing behavior of the system if not so designed, e.g. blocked out steps; only use "SP.All" to set the detuning factor in standard system.

S5.yy Duty period of step yy usage in units of 100h.

S6.yy Cycles on/off of step yy in units of 100.

The experts menu of commissioning allows to reset duty period or cycles on/off to zero individually per step or for all steps (menu items "Sd.yy", "Sc.yy" resp. "Sd.All", "Sc.All").

Caution! Reset on a single step after repair forces to intensify usage of the affected step due to get matching utilization data.

### 5.3.5 "Info" Menu Group Alarms ("A . ")

Any menu item "Ax.yy" of the "Info" **Menu Group Alarms** shows the particular reading from the information series x for alarm type yy, e.g. "A2.12" the number of over-voltage switch-offs ever occurred during the controllers life.

The following menu series are defined:

A1.yy Number of alarms of type yy since the last reset (menu item "C0.13")

A2.yy Number of alarms of type yy ever occurred during the controllers life.

Items without any occurrence are skipped using the arrow right key "→" for selection of yy; but at least the first and the last items will be shown.

The alarm types are listed in [Table 4 Alarm Types](#), page [60](#).

## 5.4 Menu Tree "Set" in Detail

### 5.4.1 Password Protection

When the service password has been set ("C0. 9", "In.16") then almost every setup value, parameter setting, or action within the menu tree "Set" is password protected. Normally all settings can be displayed without password. But if you enter the "SET" key to change the setting or to start the desired action then you have to enter the service password at first if not still active from a prior password request.

Changing some parameters requires a special password; those parameters should not be changed without permission of SYSTEM ELECTRIC or its service partners. The special password is also required due to make some menu items visible. Items not applicable to the present controller variant still remain invisible.

If requested to enter the password after using the "SET" key you may abort the whole process with "ESC" or select the password using the arrow keys. Enter the password with a second "SET". Note that due to SW artifacts the desired number entry or desired action may start immediately or not; i.e. you may be required to start number entry or action again by another "SET". These artifacts may die off on behalf of further SW enhancements.

After a password has been entered it remains valid until the controller falls back into the [Standard Screen](#) (see page [27](#)) after 3 minutes without keystroke and without long-term action or result display. In order to immediately disable an active password use password change ("C0. 9") with an invalid password. The special password also opens the service password.

### 5.4.2 Legend on Parameter Input

This chapter shows how within this document the input range and other values effective during input to parameters are schematically given in short-form

*default value* [ *minimum value* .. *maximum value* ] < *input default value* >

The squared and angle brackets, and the double dots are used just as shown. "*default value*" has been set by the SE factory settings. By means of the customized factory defaults that value may have been changed at a particular device. The "*default value*" may be "-", that means without standard value, i.e. in general zero but zero is not allowed for input "*minimum value*" and "*maximum value*" limit the range accepted on input. The optional "*input default value*" is the (mostly used) proposal from the input routine if that parameter yet never had been input.

Select lists are shown as list of values with the default underlined, e.g. "on/off", or "Auto cap / Auto ind / On cap / On ind / Off".

The value's unit may suffix the specification on input values.



### 5.4.3 Basic "Set" Group acc. Code Table ("C0. ")

The 1-dimensional **Basic Setting and Action Group** according the Code Table "Set" / "C0. " offers menu items on parameter setting, data reset, and special actions. Proceed to the next menu item using the arrow down key "↓".

The following menu items are defined:

- C0. 1 **Set parameter** Current Transducer Ratio (CTR). - [1 .. 9999] <100> (= "P0. 1")
- C0. 2 Set parameter Target Cos phi, (tariff 1). 1.00 [Ind 0.70 .. Cap 0.80] (= "P0. 2")
- C0. 3 Set parameter Alarm Cos phi (inductive threshold). Ind 0.90 [Ind 0.70 .. Cap 0.80] (= "P0. 5")
- C0. 4 Set parameter Alarm Delay Cos phi. 60 [0 .. 1440] minutes (= "P0. 7")
- C0. 5 Set param. Response Time for Contactor Steps. 15 [4 .. 3600] sec. (= "P0. 2")
- C0. 6 Set param. Idle Period for Contactor Steps. 45.0 [3.0 .. 300.0] sec. (= "P0. 3")
- C0. 7 Set binary parameter Suppress Defect Analysis / Steps Powers Sizing. on/off (= "Pb. 2") Caution, inverse presentation!: off=defect analysis on (standard), on=suppression.
- C0. 8 Restore the acknowledged and no more presented Alarms still active ("**AL...**"); start action by "SET".
- C0. 9 Set / change **Password**; start action by "SET".  
 Note: If you only want to open the controller with a special password then immediately abort password input by "ESC" when the error indication or the "Pwd.1" prompt for the new password appears; on abort past begin of new password input the special password loses validity.
- C0.10 Fan Off for 30 minutes; helpful for servicing the system
- C0.11 **Reset** min/max values of Measurement Readings ("Info" group "Mx.yy")
- C0.12 Reset max values of Harmonics Readings ("Info" group "Hx.yy")
- C0.13 Reset count of Alarm Occurences ("Info" group "A1.yy")  
 Start those actions by the "SET" key.
- C0.14 Register "Maintenance Done", Start by "SET"
- C0.15 Fan Test; toggle on/off by every keystroke on "SET"
- C0.16 Alarm Relay Test; toggle on/off by every keystroke on "SET"
- C0.17 **Repair** / Test Step (=temporary size single step as in commissioning)
- C0.18 Repair / Replace or Add Step; self size step power
- C0.19 Repair / Replace or Add Step; enter step power by hand
- C0.20 Repair / Clear defect flags without test; appears only with special password  
 Repair / Replace or Add Step is locked out during commissioning because in general the preconditions are not given there. Also commissioning provides that actions for all steps.  
 Start repair actions by "SET". After that you can select the step affected using arrow right "→". Finally start sizing or input again by "SET".

It seems as if some items of this menu group are needless because they are the same as other menu items. Note that the planned Basic variant of the Reactive Power Controller CR4.0 does not include the large, sophisticated 2-dmensional menu groups of the "Info" and "Set" menu trees.

#### 5.4.4 "Set" Menu Group Initiation ("In. ")

The 1-dimensional **Initiation Menu Group** "Set" / "In. " offers menu items used for commissioning. Proceed to the next menu item using the arrow down key "↓". Depending on the actual operation mode this menu group comprises different items.

The following menu items are defined during **Normal Operation**:

- In. 1 Revert parameter set I to the (customized) factory defaults. This action operates on the "**Standard Settings**" only, e.g. target cos phi, response time, idle period, etc. System dependent settings (set II) remain unchanged, e.g. current transducer ratio, steps powers, etc. Start action by "SET".
- In. 2 **Re-enter commissioning**. Start change of operation mode by "SET"

The following menu items are defined during **Commissioning**:

- In. 1 Revert all parameters to the (customized) **factory defaults** and clear all commissioning specific data. Thereafter the commissioning process has to be completely repeated. Start action by "SET".
- In. 2 **Automatic Self-acting Commissioning**. Start action by "SET".

The following menu items form the **Experts Menu** within commissioning:

- In. 3 Pre-programm the particular controller in **SE Mode**. on/off
- In. 4 Set parameter **Current Transducer** by **primary and secondary** current nominal values in A; the input one after another is valid as pair only.  
- [1 .. 9999] <500> : [1, 5] <5>  
The resulting ratio is displayed at parameter "In. 5". For an invalid transducer or after input of the transducer ratio this menu item is displayed as " -".
- In. 5 Set parameter **Current Transducer Ration (ctr)**. - [1 .. 9999] <100> (= "P0. 1")  
After input of the current transducer by primary and secondary nominal values in "In. 4" the calculated ratio is shown here and can be changed as ratio losing the primary / secondary value pair.
- In. 6 The **highest step number** in use (=end stop) may be entered due to speed up commissioning. Start input by "SET", decrease the displayed number to the desired value using arrow down key "↓", finally strike "SET" for acceptance or "ESC" for discard. Use the arrow right key "→" to reset the number to its maximum. During selection the affected red "Steps" LEDs are blinking.  
Caution! This setting remains valid through the next reset as desired for benefit but may get lost by the overnext reset. Please check that value if you try several commissionings.
- In. 7 Configure the **Steps Types**. Start input by "SET", select one particular step or all steps using the arrow right key "→" then open selection for the particular step by "SET". Select step(s) type(s) using arrow down key "↓", finally strike "SET" for acceptance or "ESC" for discard. You may repeat selection for another step. Use "ESC" for return or "↓" to proceed to the next item of this menu group.

In fact "In. 7" uses the menu item "St.yy". That also provides after the last step number with "St.All" to select the same step type for all steps.

The list of steps types comprises "Auto"/" CAP" and "Auto"/" Ind" for capacitive capacitor or inductive reactor steps included into automatic regulation, " On"/" CAP" and " On"/" Ind" for fixed steps (note: even fixed steps may become sized during commissioning), and " OFF" for steps out of service, e.g. reserve spare steps.

Normal operation modes only allow to change step(s) type(s) from that selected during commissioning to " OFF" and back again, e.g. for temporarily putting out of operation.

In the -4T-4K variant of the controller additionally the hardware type of the respective step is displayed as "tHYr" / "Cont" for transistor / relay outputs to thyristor switches / contactors.

In. 8 **Self gauge the Network Configuration**, i.e. the system dependent phase angle between voltage and current, the nominal mains voltage, and the nominal mains frequency, using the same routines as the automatic self commissioning process. Start action by "SET"

In. 9 **Enter the Network Configuration** by hand as pin assignment like L2-L3;L1,k-l using a 4-digits number, here. "2311". Start input by "SET". The leftmost digit specifies KLEMME\_U1=pin 1 of the connector strip with 0=N, 1=L1, 2=L2, and 3=L3, followed by KLEMME\_U2=pin 3, 1\_PHASE=phase including the current transducer connected to pins 8/9, and the rightmost digit specifies the polarity of the current transducer with 1=k-l for regular polarity, and 2=k-l for inverted polarity.

Invalid combinations are not accepted. The resulting system dependent phase angle is displayed in menu item "In.10". After gauging the network configuration or direct input of the phase angle " -" id displayed.

In.10 Enter the network configuration by hand but only the system dependent **phase angle**. Start input by "SET", select the degrees value from a list using the arrow down key "↓", finally strike "SET" for acceptance or "ESC" for discard. Multiples of 30° [0° .. 360°(=0°)]

Note! With this menu item the nominal mains frequency will not get set!

Phase-angle	x-y; L1, k-l	x-y; L2, k-l	x-y; L3, k-l	x-y; L1, l-k	x-y; L2, l-k	x-y; L3, l-k
0°	L1-N; L1, k-l	L2-N; L2, k-l	L3-N; L3, k-l	N-L1; L1, l-k	N-L2; L2, l-k	N-L3; L3, l-k
30°	L1-L2; L1, k-l	L2-L3; L2, k-l	L3-L1; L3, k-l	L2-L1; L1, l-k	L3-L2; L2, l-k	L1-L3; L3, l-k
60°	N-L2; L1, k-l	N-L3; L2, k-l	N-L1; L3, k-l	L2-N; L1, l-k	L3-N; L2, l-k	L1-N; L3, l-k
90°	L3-L2; L1, k-l	L1-L3; L2, k-l	L2-L1; L3, k-l	L2-L3; L1, l-k	L3-L1; L2, l-k	L1-L2; L3, l-k
120°	L3-N; L1, k-l	L1-N; L2, k-l	L2-N; L3, k-l	N-L3; L1, l-k	N-L1; L2, l-k	N-L2; L3, l-k
150°	L3-L1; L1, k-l	L1-L2; L2, k-l	L2-L3; L3, k-l	L1-L3; L1, l-k	L2-L1; L2, l-k	L3-L2; L3, l-k
180°	N-L1; L1, k-l	N-L2; L2, k-l	N-L3; L3, k-l	L1-N; L1, l-k	L2-N; L2, l-k	L3-N; L3, l-k
210°	L2-L1; L1, k-l	L3-L2; L2, k-l	L1-L3; L3, k-l	L1-L2; L1, l-k	L2-L3; L2, l-k	L3-L1; L3, l-k
240°	L2-N; L1, k-l	L3-N; L2, k-l	L1-N; L3, k-l	N-L2; L1, l-k	N-L3; L2, l-k	N-L1; L3, l-k
270°	L2-L3; L1, k-l	L3-L1; L2, k-l	L1-L2; L3, k-l	L3-L2; L1, l-k	L1-L3; L2, l-k	L2-L1; L3, l-k
300°	N-L3; L1, k-l	N-L1; L2, k-l	N-L2; L3, k-l	L3-N; L1, l-k	L1-N; L2, l-k	L2-N; L3, l-k
330°	L1-L3; L1, k-l	L2-L1; L2, k-l	L3-L2; L3, k-l	L3-L1; L1, l-k	L1-L2; L2, l-k	L2-L3; L3, l-k

Table 3	Pin Assignment versus system dependent Phase Angle (all permutations) e.g. 270°=L2-L3; L1, k-l denotes voltage measurement from L2-L3 with L2 at pin 1; current measurement in L1, transducer output k (=S1) at pin 8 The first column with x-y; L1, k-l is the preferential representation
---------	---

**In.11 Enter the network configuration by hand but only the **nominal mains voltage** in V**

The mains voltage is connected to the capacitor bank, usually 400V, also with 230V as measuring voltage L-N.

Note: All steps powers are computed to nominal voltage and frequency.

Caution! With this menu item the nominal frequency gets fixed.

**In.12 Fixed Compensation Power / Basic Load** in kvar - [0.0 .. 999.9] with the "Cap"/"Ind" LEDs as sign for a capacitive power (e.g. for transformer compensation) resp. inductive power (e.g. for regulation outside the capacitive quadrants, parallel shifting of the target band). Fixed compensation power / basic load is an alternative for fixed steps.

Fixed compensation power / basic load can be pre-programmed in SE mode in kvar. - [0.0 .. 910.2]. The input value is internally stored to an SE mode specific scale and converted into the calibration dependent internal scale when net configuration and transducer have been set during commissioning.

**In.13 Enter the Steps Powers** by hand in kvar - [0.0 .. 999.9] <50.0>. Start input by "SET", select one particular step or all steps using the arrow right key "→". Use "SET" to open input for the particular step, input the power in kvar, and finally strike "SET" for acceptance or "ESC" for discard. Use "ESC" for return or "↓" to proceed to the next item of this menu group.

Note: All measuring values as well as settings like steps powers are internally stored as values normalized to a given maximum. Thus your input is rounded to the next internally representable value. For SE Mode the scale is fixed while the normal operation values depend on the maximum network size defined among other things by the controller's calibration and by the transducers ("In. 4", "In. 5"). Steps powers to big or to small are not accepted visible by an unchanged value after input. The controller also uses a kind of mains fidget to determine the lowest acceptable step power, see [Smallest Step Power](#), page 71.

In fact "In.13" uses the menu item "S0.yy". That also provides after the last step number with "S0.All" to enter the same step power for all steps, input default value is 50kvar.

Please select the steps types (cap/ind, auto/on) prior to self sizing or entering steps powers for predictable results. Later type changes may cause perplexing artefacts for you, despite the controller always acts right.

**In.14 Self Size the Steps Powers** using the same routines as the automatic self commissioning process. Start action by "SET"

When SE-Mode is active this item at first determines the current transducer ratio (ctr). After a plausibility check it unchangingly accepts

the pre-set powers; if the check fails then sizing resumes in standard operation ("ModE"/"Std. ").

- In.15 Change to the **Automatic Regulation Mode (Auto)**. Start by "SET"  
Error indications "Err.2" or "Err.3" may result if mode change could not be executed because not all prerequisites are available (current transducer, net configuration, steps powers). Possibly those error indications may also occur if all prerequisites are available but have been setup in a different order; then try this menu item again after the reset following the error indications because reset clears all information on execution order.
- In.16 Set / change Password. Start action by "SET".  
Note: If you only want to open the controller with a special password then immediately abort password input by "ESC" when the error indication or the "Pwd.1" prompt for the new password appears; on abort past begin of new password input the special password loses validity.
- In.17 Change binary parameter **Show Results**. on/off (= "Pb. 5")
- In.18 Change binary parameter **Detail Info**. on/off (= "Pb. 4")  
When on the single results for every switching of a step are shown. Skilled service staff can already during the gauging / sizing process detect if that process runs out of the rudder.
- In.19 **Power-free Output Test** for the wiring controller <-> capacitor bank, in particular useful for multi-cabinett systems. Start test by "SET"  
**Caution! To be used only with power-free steps** because neither the idle period is obeyed nor mains alarms are respected!
- In.20 Store the actual parameter set I "Standard Settings" as **customized factory defaults**.
- In.21 Revert parameter set I to the original **SE factory defaults**.  
This actions operates on the "Standard Settings" only, e.g. target cos phi, response time, idle period, etc. System dependent setting remain unchanged, e.g. current transducer ratio, steps powers, etc. Start action by "SET".

It seems as if some items of this menu group are needless because they are the same as other menu items. Note that the planned Basic variant of the Reactive Power Controller CR4.0 does not include the large, sophisticated 2-dimensional menu groups of the "Info" and "Set" menu trees.

#### 5.4.5 "Set" Menu Group Steps ("S . ")

Any menu item "Sx.yy" of the **"Set" Menu Group Steps** provides access to settings or readings related to the capacitor bank, e.g. "Sc. 7" shows the number of cycles on / off of step 7 within the capacitor bank and allows to clear that value to zero. All actions or changes are allowed only from the commissioning mode; in normal operation the values can be displayed only; one exception exists: in normal operation the type of a single or all step(s) may temporarily be changed to " OFF" or back again due to prevent those steps from usage by the automatic regulation.

Between the last step and the first one "1" often the menu item "Sx.All" exists due to extend the action or change to all steps.

The following menu series are defined:

**St.yy** Configure the **Steps Types**. Start input by "SET", select one particular step or all steps using the arrow right key "→". Open selection by "SET", then select particular step(s) type(s) using wizj the arrow down key "↓", finally strike "SET" for acceptance or "ESC" for discard. Use "St.All" to configure all steps for the same type.

The list of steps types comprises "Auto"/"CAP" and "Auto"/"Ind" for capacitive capacitor or inductive reactor steps included into automatic regulation, "On"/"CAP" and "On"/"Ind" for fixed steps (note: even fixed steps may become sized during commisiioning), and "OFF" for steps out of service, e.g. reserve spare steps.

Normal operation modes only allow to change step(s) type(s) from that selected during commissioning to "OFF" and back again, e.g. for temporarily putting out of operation.

In the -4T-4K variant of the controller additionally the hardware type of the respective step is displayed as "tHYr" / "Cont" for transistor / relay outputs to thyristor switches / contactors.

**S0.yy** **Initial Step Power** in kvar with 1 decimal place for input (1 or no decimal place for simple display). - [0.0 .. 999.9] <50.0>

Start input by "SET", select one particular step or all steps using the arrow right key "→". Open input for particular step(s) by "SET", then input the power in kvar, and finally strike "SET" for acceptance or "ESC" for discard.; use another "ESC" for return to this menu group.

Note: All measuring values as well as settings like steps powers are internally stored as values normalized to a given maximum. Thus your input is rounded to the next internally representable value. For SE Mode the scale is fixed while the normal operation values depend on the maximum network size defined among other things by the controller's calibration and by the transducers ("In. 4", "In. 5"). Steps powers to big or to small are not accepted visible by an unchanged value after input. The controller also uses a kind of mains fidget to determine the lowest acceptable step power, see [Smallest Step Power](#), page 71. input default value is 50kvar.

Please select the steps types (cap/ind, auto/on) prior to entering steps powers for predictable results. Later type changes may cause perplexing artefacts for you, despite the controller always acts right.

Steps powers can be pre-programmed in SE mode in kvar. - [0.0 .. 910.2]. The input value is internally stored to an SE mode specific scale and converted into the calibration dependent internal scale when net configuration and transducer have been set during commissioning.

**SP.yy** **Detuning factor** in percent with 2 decimal places. 7.00 [0.00 .. 40.00].

May be individual per step due to obtain a kombi-detuned or absorption-circuit system ("Pb. 9" == "On"/"OFF"). Note that any difference in detuning factors to any digit activates that special type of regulation with confusing behavior of the system

if not so designed, e.g. blocked out steps; only use "SP.All" to set the detuning factor in standard systems.

- Sd.yy **Duty period** of step yy in units of 100h. Strike "SET" to clear that value  
 Sc.yy **Cycles on/off** of step yy in units of 100. Strike "SET" to clear that value  
 Strike "SET" at "Sd.All" or "Sc.All" to clear the values of all steps to zero.  
 Caution! Reset on a single step after repair forces to intensify usage of the affected step due to get matching utilization data.

#### 5.4.6 "Set" Menu Group Parameter ("P . ")

With the menu items "Px.yy" of the **"Set" Menu Group Parameter** the behaviour of the Reactive Power Controllers CR4.0 can be customized to match the customers requirements, e.g. "P0. 4" adjusts the target cos phi.

Although the menu group Parameter is set up as 2-dimensional matrix however it works as an 1-dimensional list of menu series x comprising each an 1-dimensional list of menu items yy. The difference to a 2-dimensional matrix is that the next menu item from "Pb. 4" with the arrow down key "↓" is "P0. 1" not "P0. 4".

Following menu series are defined:

- PA.yy **Alarm Relay Parameter** determine which alarms should be reported via the alarm relay to an external alarm light or to a management system.  
 Pb.yy **Binary Policy Parameter** have either one or the other state  
 P0.yy **Common Parameter Set.** The settings appear in different number representations, e.g. cos ph typei, simpel number with 0 .. 2 decimal places, number pair, hexadecimal, etc  
 PI.yy Configuration of the **Control Interface** (CI) ("tariff 2-input")  
 PC.yy Configuration of the **Communications Interface**, if applicable

##### 5.4.6.1 Menu Series Alarm Relay Parameter ("PA. ")

The **Alarm Relay Parameter** define which particular alarm reasons should be reported via the alarm relay to a signal light or to a management system With factory default all alarm sources are enabled (=on).

Following alarm sources are defined:

- PA. 1 Cos phi to inductive ("AL. 1")  
 PA. 2 Cos phi to capacitive ("AL. 2")  
 PA. 3 Steps Power Derating to big ("AL.31" .. "AL.38")  
 PA. 4 Steps Duty Period exceeded ("AL.41" .. "AL.48")  
 PA. 5 Steps Cycles on/off exceeded ("AL.51" .. "AL.58")  
 PA. 6 Measuring Voltage below threshold Umin ("AL.11")  
 PA. 7 Measuring Voltage above threshold Umax ("AL.12")  
 PA. 8 Measuring Voltage below metering range or continued zero voltage ("AL.16", "AL.10")  
 PA. 9 Measuring Voltage above metering range ("AL.17")

- PA.10 Measuring Current above metering range ("AL.18")
- PA.11 Voltage Harmonics exceeds threshold, THDU or single harmonics ("AL.21", "AL.20")
- PA.12 Frequency Alarm ("AL.23")
- PA.13 Temperature Alarm ("AL.24")
- PA.14 Internal Error without Reset, e.g. supply power low ("AL.25")
- PA.15 Internal Error, reported after Reset, e.g. software error, pendular alarm switch offs ("AL.29", "AL.30")

The setting of the alarm relay parameters is stored as bit pattern amongst the common parameters.

#### 5.4.6.2 Menu Series Binary Policy Parameter ("Pb. ")

The **Binary Policy Parameter** define which particular methods apply to regulation, steps management, alarming, and man machine interface. With factory default all binary policy parameter are off (note the inverse wording of some parameter definitions therefore).

Following binary policy parameters are defined:

- Pb. 1 Capacitive-free regulation, target band angled
- Pb. 2 Suppress Defect Analysis / Steps Powers Sizing. on/off. Caution, inverse presentation!: off=defekt analysis on (standard), on=suppression.
- Pb. 3 No Thyristor FAST Mode (i.e.the -4T4K or -8T variant does not use the super-fast regulation algorithm with a characteristic response time of 25 msec)
- Pb. 4 Detail-Info. During Commissioning show the single results measured during switching of a single step, either step power or phase angle. (Parameter bit switches off when changing from commissioning to the automatic regulation mode.)
- Pb. 5 Suppress result presentation after gauging and sizing during commissioning (menu item is visible only during commissioning mode.)
- Pb. 6 Contactors switch all together (= "on") or one after another (= "off") (menu item is visible only during commissioning mode.)
- Pb. 7 Contactors switch on despite  $U < U_{\min}$ . This setting may be useful for voltage measurement L-L if the compensated mains network suffers from frequent voltage drops however the controller supply comes from a separate stable mains. (menu item is visible only during commissioning mode.)
- Pb. 8 The cabinet fan (if switched by the controller) works not only according to the measured temperature but also if at least one thyristor switch is on due to cool down the waste heat of the thyristor switch itself (menu item is visible only in the -4T4K or -8T variants of the controller)
- Pb. 9 On mixed detuning factors regulation according to the combi detuning model (=on), i.e. every moment there is an equal amount or slightly more step power switched on with the higher detuning as with the lower detuning, or the absorption circuit model (=off), i.e. steps with the lower detuning factor will no be switched on unless all steps with the higher detuning factor are on (note: this will be blocking for the lower detuned steps if any higher detuned step goes out of service).



*Pb.10 Cos phi alarms also occur during low load if the granularity of the system's steps does not allow to reach the target cos phi, i.e. the alarm threshold alone dictates whether a cos phi alarm is present or not  
This menu item is obsolete; please track the discussions!*

The setting of the binary policy parameters is stored as bit pattern amongst the common parameters.

### 5.4.6.3 Menu Series Common Parameter ("P0. ")

With the menu series **Common Parameter** the most important configurations that exists inside the Reactive Power Controller CR4.0 can be adjusted. Besides the about 30 Parameters presented here for control by the customer / service staff all the about 120 internal parameters are accessible by the service staff authorized by SYSTEM ELECTRIC Power Quality GmbH on base of the software sources used to build the present version.

The common parameters use different number representations (e.g. cos phi, simpel number with 0.. 2 decimal places, number pair, hexadecimal, etc.) specified with the respective item description. When selecting a special item with the arrow right key "→" assure to strike the right one by watching the item number at the numerical display because if not applicaple (wrong controller variant, special password not entered, etc.) some items will be omitted during scrolling with "→".

Please note that the following list of menu items may vary dependent on the software version ("c1. 7").The short form guide you got on delivery always applies to your software version. If lost download the respective papers from the manufacturer's homepage ([www.system-electric.de](http://www.system-electric.de)):

- P0. 1 Current Transducer Ratio.** - [1 .. 9999] <100> (= "C0. 1", "In. 5").  
On delivery this parameter is set to zero due to indicate a yet unspecified parameter. Internally zero acts as 1 (5A:5A); at first input 100 (500A:5A) is proposed.
- P0. 2 Response Time for Contactor** switched steps in seconds. 15 [4 .. 3600] (= "C0. 5").  
The response time determines how long the controller watches / means the network requirements to reach the target cos phi until updating the switching combination of the capacitor bank. The response time value applies to a requirement change of 2 times the smallest step power or more from a completely compensated state. This is the shortest period that is dynamically prolonged up to 10 times for smaller requirements.  
Nevertheless a shorter response period may be observed if the regulation process had been pre-loaded, i.e. if prior to the observed network change there was already a smaller requirement for switching in the same direction but the time had not become "mature" for switching.
- P0. 3 Idle Period for Contactor** switched steps in seconds. 45.00 [3.00 .. 99.99] (= "C0. 6").  
Idling prevents from re-connecting any charged capacitor with opposite phases. This works by discharging the capacitors after switching off by

standard resistors to a low voltage level. In any case discharging is also necessary due to protect the service staff from electric shock. Inductive reactor steps and thyristor switched steps need no discharging.

P0. 4 **Target Cos phi.** Unit-free number ( $\leq 1.00$ ) with 2 decimal places and with the "Cap"/"Ind" LEDs as sign. 1.00 [Ind 0.70 .. Cap 0.80] (= "C0. 2").

P0. 5 **Cos phi Alarm Threshold** towards the inductive side. (= "C0. 3")

P0. 6 **Cos phi Alarm Threshold** towards the capacitive side.

Same input ranges as at target cos phi; All three parameters can be set to the same value.

With tariff changeover programmed at "PI. 1" valid for tariff 1.

P0. 7 Alarm Delay for cos phi alarms in minutes. 60 [0 .. 1440 (=24h)] (= "C0. 4")

P0. 8 Fixed Compensation Power / Basic Load in kvar - [0.0 .. 999.9] with the "Cap"/"Ind" LEDs as sign for a capacitive power (e.g. for transformer compensation) resp. inductive power (e.g. for regulation outside the capacitive quadrants, parallel shifting of the target band). Fixed compensation power / basic load is an alternative for fixed steps.

The basic load / fixed compensation power is added to the reactive power demand to reach the target cos phi. The first application was to compensate the transformer's inductive idling load at compensation systems at low voltage but with the utility provider measuring at the medium voltage. Thus the standard screens show the extrapolated cos phi at the medium voltage side of the transformer. In the measurement readings both cos phi are available: the HV-cos phi.B (= "Mx.10") and the NV-cos phi.T (= "Mx.11") that can be directly measured at the low voltage system.

In general for compensation of the transformer's inductive idling load the following capacitive basic loads should be considered (transformer size - basic load): 250kVA - cap. 5kvar, 400kVA - cap. 7,5kvar, 630kVA - cap. 12,5kvar, 1250kVA - cap. 25kvar.

Use an inductive basic load / fixed compensation in size of the smallest step power due to get a toward the inductive parallel shifted target band of regulation.

The fixed compensation / basic load is capable to be pre-programmed in SE mode-

P0. 9 **Alarm Threshold THDU** in percent. 3.0/7.0/9.0 acc.detuning [0; 2.0 .. 45.0]

P0.10 **Alarm Threshold single Harmonics in percent.** 3.0/6.0/8.0 [0; 2.0 .. 45.0]

The default value changes according to the detuning factor; undetuned  $p < 2\%$  normal detuning/  $2\% \leq p < 10\%$  / highly detuned  $p \geq 10\%$ . A threshold of 0% de-activates alarming.

P0.11 **Alarm Delay for harmonics alarms in minutes.** 5 [2 .. 20]

Alarm ends for the alarm delay after the alarm reason vanished but not before three times the alarm delay after alarm begin.

P0.12 **Alarm Threshold  $U_{max}$**  in percent of the nominal mains voltage (at L-N calculated using the catenation factor). 112% [105% .. 115%]

The  $U_{max}$  alarm switch-off prevents from over-stressing the capacitors.

P0.13 **Alarm Threshold  $U_{min}$**  in percent of the nominal mains voltage (at L-N calculated using the catenation factor). 88% [85% .. 95%]

The  $U_{min}$  alarm switch-off prevents from incomplete switching on of contactors; with a contactor supply voltage from a separate stable mains the linkage of  $U_{min}$  alarm and capability for switch on may be repealed as it is with thyristors, menu item "Pb. 7".

Passing over  $U_{\max}$  or passing below  $U_{\min}$  only results in alarm switch-off after the alarm delay long period ("P0.14"). In contrast the alarm switch-off for zero voltage ( $U < 75\% U_{\text{mains acc. norm}}$ ) is triggered after about 20 msec due to prevent from switching on the capacitors with opposite voltage. Note that zero voltage alarms shorter than the alarm delay long are counted only but not presented to the customer / service staff due to calm minds.

- P0.14 Alarm Delay Long / Dead Time on Inrush in seconds.** 5.00 [0.00 .. 20.00]  
 This is the alarm delay for  $U_{\min}$ ,  $U_{\max}$ , and  $I >$  metering range. As the dead time on inrush this parameter prevents the Reactive Power Controller CR4.0 to execute an alarm switch-off merely because a machine starts-up and draws inrush current beyond the controllers metering range. During inrush a fully compensated network is pretended to the regulation algorithm.
- P0.15 Alarm Threshold Step Power Derating.** 20% [5% .. 30%]  
 Does the loss of step power exceed that threshold the single affected step is switched off and marked as defective due to prevent from frequent switching because of inconstantly measured step power and due to prevent from fire danger because of loose contact.. Prior to alarming a blamed step is twice tested while already out of service. With a step power near to the resolution limit (see chapter [Smallest Step Power](#) on page 71) the tolerance band results in a vagueness dependent on mains fluctuations ("Streubreite"). Therefore the limit is granular and a particular threshold may be e.g. 22% despite a setting of a 20%..
- P0.16 Alarm Threshold Cycles On/off in one hundred.** 1000 [100 .. 3000]  
 The default value 1000 means  $1000 \times 100 = 100'000$  cycles on/off.
- P0.17 Alarm Treshold Duty Period in one hundred hours.** 800 [100 .. 1500]  
 The default value 800 means  $800 \times 100 = 80'000$  hours or about 9 years.  
 Cycles and duty period alarms are only notices on required service and do not initiate an alarm switch-off on the affected step.
- P0.18 Temperature Alignment in degrees Celsius.** 0 [-10 .. +10]  
 This parameter value is subtracted from the raw value measured by the sensor at the rear of the controller case. The subtraction result is shown by menu item actual temperature ("M1.12") and is used for fan control and alarming. For e.g. a temperature at the capacitors that is in the operational area typical by 3°C higher than the temperature at the controller's sensor should be input as -3 to that parameter due to especially consider the capacitor temperature.
- P0.19 Fan On Temperature for the cabinet fan in degrees Celsius.** 30 [25 .. 40]  
 The fan is switched off when the temperature fall by 5°C below the on-temperature. Note that older systems from SYSTEM ELECTRIC use a separate mechanical bimetal switch to control the cabinet fan.
- P0.20 Alarm Threshold Excess Temperature in degrees Celsius.** 48 [35 .. 65]
- P0.21 Alarm Delay Excess Temperature in minutes.** 15 [0 .. 240]  
 A few seconds after the cabinet temperature rises above 3°C below the alarm threshold excess temperature the controller issues the alarm indication "AL. 9" as warning in advance. After the cabinet temperature exceeds the alarm threshold for at

least the alarm delay the excess temperature alarm "AL.24" replaces the advance warning and performs an alarm switch-off of all steps.

Alarm switch-off and excess temperature alarm are cleared after the cabinet temperature has been fallen by the excess temperature hysteresis (standard: 13°C) below the excess temperature alarm threshold (standard: 48°C-13°C=35°C) for at least the alarm delay excess temperature. Clearing can be forced in hot countries by turning-off the controller's supply voltage when the temperature has fallen below the advance warning threshold (std: 48°C-3°C=45°C).

Immediately after the cabinet temperature has risen by 15°C above the alarm threshold excess temperature (=63°C at std.) the controller permanently enters the out of operation mode ("StoP") and the fan is switched off due to prevent from fire acceleration. The same happens at a very fast temperature rise, i.e. at >5°C per minute above 35°C to exclude temperature rises by closing the cabinet door. After that the controller must be manually restarted by striking both green keys together for about 3 seconds.

Beneath the excess temperature alarm there is an alarm threshold cold. If the cabinet temperature falls below -10°C (standard) for at least the alarm delay the alarm excess temperature "AL.24" is released, too. Due to clear the alarm switch-off the alarm threshold cold must be exceeded for the alarm delay period; turning-off the controller's power supply may force restart of operation.

- P0.22 Limitation of Steps Powers Sum** for switching altogether in percent in relation to the largest single step in the capacitor bank. 832 [104% .. 832%]  
If the sum of steps powers involved into a switching operation for thyristor switches or for contactor in the switching altogether mode (menu item "Pb. 6") exceeds this limit then the switching operation is split into at least two operations like the contactor switches one after another mode. In fact this limitation does separately apply to switching on resp. off. The default value allows all the 8 steps to operate altogether because it is 8 times the largest step power.
- P0.23 Response Time for Thyristor** switched steps in msec. 0 [0; 40 .. 8000]  
(0=as short as possible=ca. 35ms dependent on internal characteristics.)  
The response time determines how long the controller watches / means the network requirements to reach the target cos phi until updating the switching combination of the capacitor bank. The response time value applies to a requirement change of 2 times the smallest steps power or more from a completely compensated state. This is the shortest period that is dynamically prolonged up to 10 times for smaller requirements.  
Nevertheless a shorter response period may be observed if the regulation process had been pre-loaded, i.e. if prior to the observed network change there was already a smaller requirement for switching in the same direction but the time had not become "mature" for switching.  
This menu item is visible only in a thyristor switching controller variant -4T4K or -8T.
- P0.24 Idle Period for Thyristor** switched capacitor steps in seconds.  
0 [0; 0.02 .. 90.00]. (0=as short as possible=included in the physical switching delay.)  
The specific method of thyristor switches to connect the capacitors at zero voltage difference eliminates the necessity to discharge the capacitor prior to re-connection.

However an idle period may be required because most thyristor switches cannot **re-connect all phases** before systemic voltage differences have been eliminated. That requires up to 3.5sec with the standard discharge resistors resp. a few hundred msec with heat spitting fast-discharge resistors. The **thyristor switch CT2000** from SYSTEM ELECTRIC is able to accept the re-connection command as fast as **40msec** after the command withdrawel and executes it for all phases within max. 25msec without the need for discharging the capacitor. The CT200 does not require any idle period and can be switched more than 12 times on/off within 1 second !

This menu item is visible only in a thyristor switching controller variant -4T4K or -8T.

- P0.25 **Response Time for contactor switched follower steps** in the controller variant -4T4K in seconds. 0 [0 .. 3600] (0=as fast as possible)

A follower contactor step switches on only if all thyristor switches are on and demand for on continues resp. switches off only if all thyristor switches are off and demand for off continues. This response time slows down the follow up operation due to reduce switching operations on account of short times with uncompensated reactive power. Also consider the idle period for contactors

This menu item is visible only in the controller variant -4T4K.

- P0.26 **Transducer Phase Error Correction** in angle minutes. -45 [-900 .. +900]

This parameter has been preset for a typical class 1.0 current transducer loaded by two third the nominal load. If you use a summing transducer or special equipment inside the current measuring loop use this parameter to correct phase shifting and thus balance reactive power measurement. Note that the phase error inserted by a voltage transducer must here be added with reversed sign.

- P0.27 **Test Cycles number for the Output Test.** 5 [1 .. 2000]

- P0.28 **Test Interval for the Output Test** in seconds. 2.00 [1.00 .. 60.00]

Note that a cycle switching on and off requires 2 times the test interval.

The output test is used by the system manufacturer or the system installer to check the wiring between controller and capacitor bank. During the output test the capacitor bank must be disconnected from mains supply because this test does not care about idle periods.

- P0.29 **Secondary Side Current Transducer Overload** in A. The controller itself obtains this value. Enter zero due to restart the evaluation.

This menu item is protected by the special password. Please ask service staff authorized by SYSTEM ELECTRIC Power Quality GmbH for changes.

- P0.30 **Fixed Frequency** in Hertz. 0 [0; 45.00 .. 65.00] (0=automatic detection)

In seldom cases where frequency converters are used, or when the voltage curve is far beyond a sinusoidal curve, or in isolated networks the controller may not be able to steadily determine the mains frequency from the measured voltage despite it is quite constant. Then you may program a fixed frequency.

Caution! With a wrong frequency regulation works inaccurate and the

harmonics seem to be rising. Artefacts are visible already with 0.5Hz deviation; beyond a deviation of about 3Hz all measurement is waste!

This menu item is protected by the special password. Please ask service staff authorized by SYSTEM ELECTRIC Power Quality GmbH for changes.

#### 5.4.6.4 Menu Series Control Interface (CI) ("PI. ")

The Control Interface constitutes the system input line, e.g. for signalling tariff change daylight / night, force regulation modes, enter tracking signals, etc.

The control interface is composed as DC analogue current interface 4-20mA. It may be used as digital input (4mA±tolerance=logical "1"; other currents=logical "0"). The third pin is to alternatively apply 230V AC for a digital logical "1".

Use the parameters of "Set" menu series control interface due to configure the control interface hardware and interface protocols. Because some configuration may be used also without the interface hardware the menu series control interface "PI. " is available in every controller variant regardless of existent hardware.

##### PI. 1 Control Interface Type. Bit pattern in hexadecimal notation.

The least significant 4 bits configure the mode of the digital CI interface:

0000 / 0001	Tariff Change 1 / 2. 4mA=logical "1"= tariff 1 / tariff 2
0004 / 0005	Remote control: System on/off. 4mA= system off / on
0008 / 0009	Dual Utility Feed with section switch. 4mA=switch on / off
000C / 000D	Synchronize the quarterly readings to an external clock. Controller's quarter of hour begins with logical "1"=4mA / with logical "0"=4mA end
000E	Internal Tariff Change 1 / 2. Raw measuring current $I_M < 0.5A$ (at 5A input; 0.1A@1A) makes tariff 2, above that threshold=tariff 1

The leftmost 3 digits of the interface type control the analogue modes. Usage of the analogue CI tracking input are controlled by the second rightmost digit (here stands 4mA as the lowest tracking input, 20mA as highest; the LEW specific input signal uses 12mA as neutral input to a signed signal).

The regulation curves are defined by the two leftmost digits. The second leftmost digit determines to which curve tracking the CI input or the real power reading follows. The leftmost digit determines to which curve tracking the voltage reading follows.

The following regulation curves are defined:

0500	Regulation Curve cos phi (P) acc. VDE AR-4105:2007
0150	Regulation Curve cos phi (CI-Signal), LEW specific
0110	Regulation Curve cos phi (CI input), general
0100	Regulation Curve cos phi (P), general
1000	Regulation Curve cos phi (U), general
0220	Regulation Curve reactive power Q (CI input), general

0200 Regulation Curve reactive power Q (P), general

2000 Regulation Curve reactive power Q (U), general

Most of the regulation curves without CI involvement may be combined with a digital CI input mode. Also a regulation curve controlled by U can be combined with the appropriate curve controlled by either P or the CI input. For that enter the or-ed bit pattern into parameter "PI. 1". The controller rejects inadequate bit patterns by clearing the not accepted changes; please check after input whether the controller has accepted your bit pattern. Note that because of the complexity the controller is not able to reject every absurd bit combination.

After defining the digital mode and the regulation curves the particular configuration can be input to the sub-menus. The sub-menu for the digital modes is permanently available while the curve menus become available only if the corresponding mode has been activated. After return from such a sub-menu the controller clears the mode / curve settings with incomplete or bad configuration settings; please check after in "PI. 1" whether the controller has kept your bit pattern..

- PI. 2 Sub-menu parameters of the digital CI modes; enter with the "SET" key
- The numerical 7-segment display shows the current through the CI input in terms of 1/10 mA. Note that the CI interface is not intended as measuring input; a metering error of 10% is no reason for blaming. On account to the simple design and because of using standard devices the result is limited to about 18.5mA.
- PI.21 Target cos phi, tariff 2, plain number  $\leq 1.00$  with 2 decimal places and with the "Cap"/"Ind" LEDs as sign. ind 0.95 [ind 0.70 .. cap 0.80]
- PI.22 Alarm threshold cos phi towards the inductive, tariff 2. ind 0.90 [...]
- PI.23 Alarm threshold cos phi towards the capacitive, tariff 2. cap 0.98 [...]
- Same input ranges like target cos phi. All three parameters can be set to the same value. Parameters for tariff 1, see "P0. 4" to "P0. 6"
- PI.24 Current Transducer primary / secondary in A (= "In. 4"); input both values one after another; if at last entered as ratio or gauged via SE mode the display shows " -". For dual utility feed this setting is valid for the section switch=off (=tariff 1).
- PI.25 Current Transducer primary in A. For dual utility feed this setting is valid for the section switch=on (=tariff 2) to be used with the secondary setting in "PI.24"
- PI.26 *Phase error correction, tariff 2 for dual utility feed. Yet not used.*
- PI.27 Current Transducer ratio for dual utility feed is gauged for the section switch=on (=tariff 2). Start action by "Set".

PI. 3 Sub menu parameters of regulation curve cos phi (P) according VDE AR-4105:2007; enter with the "SET" key

PI.46 Rated real power  $P_{max}$  to be feed into mains in kW

PI.47 Demanded displacement factor cos phi when feeding the rated real power, plain number  $\leq 1.00$  with 2 decimal places and with the "Cap"/"Ind" LEDs as sign. - [ind 0.70 .. cap 0.80] <ind 0.90>.

PI.48 Application point for regulation acc. curve in kW; please calcute that value yourself by multiplication of the demanded percentage by the rated real power  $P_{max}$

Applying this regulation curve the system feeds small real powers into mains at  $\cos \phi = 1.00$ . Real powers above the application point are feed with a displacement factor that is linear interpolated until it reaches the demanded displacement factor ("PI.47") at the rated real power ("PI.46"). Real powers above the rated one are fed at constant demanded displacement factor. For real power consumption from the mains the controller acts as ordinary reactive power compensation with tariff 1/2 support. Systems for that regulation curve usually need inductive reactor steps.

PI. 4 Sub menu parameters of regulation curve cos phi (CI input), LEW-Type; enter with the "SET" key

PI.36 Displacement factor cos phi at a CI input current=4mA

PI.37 Displacement factor cos phi at a CI input current=20mA.

Plain number  $\leq 1.00$  with 2 decimal places and with the "Cap"/"Ind" LEDs as sign. - [ind 0.70 .. cap 0.80]

Both cos phi values have to be symmetrical around 1.00 due to have the neutral center point 1.00 at the center CI input=12mA.

Depending on the parameter settings a system for that regulation curve may need inductive reactor steps.!

PI. 5 Sub menu parameters of regulation curve cos phi (CI input), general; enter with the "SET" key

PI.36 Displacement factor cos phi at a CI input current=4mA

PI.37 Displacement factor cos phi at a CI input current=20mA.

Plain number  $\leq 1.00$  with 2 decimal places and with the "Cap"/"Ind" LEDs as sign. - [ind 0.70 .. cap 0.80]

Depending on the parameter settings a system for that regulation curve may need inductive reactor steps.!

PI. 6 Sub menu parameters of regulation curve cos phi (P), general; enter with the "SET" key

PI.41 Lower / left application point of the regulation curve in kW



- PI.42 Displacement factor  $\cos \phi$  at the lower / left application point
- PI.43 Upper / right application point of the regulation curve in kW
- PI.44 Displacement factor  $\cos \phi$  at the upper / right application point  
Plain number  $\leq 1.00$  with 2 decimal places and with the "Cap"/"Ind" LEDs as sign. - [ind 0.70 .. cap 0.80]

It does not matter whether both application point reside within the same quadrant I .. IV or reside on two sides around the zero origin, e.g. ind 0.90 at a maximum injection of -100 kW to cap 0.95 at a maximum consumption of +150 kW. In this example the controller feeds large real power  $< -100$  kW (signed value! negative=injection) with a constant  $\cos \phi$  of ind 0.90; between -100 kW and +150 kW the  $\cos \phi$  linearly rises up to cap 0.95; at large consumption  $> +150$  kW compensation reaches a constant  $\cos \phi$  of cap 0.95. Depending on the parameter settings a system for that regulation curve may need inductive reactor steps.!

- PI. 7 Sub menu parameters of regulation curve  $\cos \phi$  (U), general; enter with the "SET" key
- PI.51 Lower application point of the regulation curve in V
- PI.52 Displacement factor  $\cos \phi$  at the lower application point
- PI.53 Upper application point of the regulation curve in V.  
The voltages must be input at the voltage level of the mains voltage (e.g. 400V), not at the voltage level of measuring  $U_M$  (e.g. 230V) !
- PI.54 Displacement factor  $\cos \phi$  at the upper application point  
Plain number  $\leq 1.00$  with 2 decimal places and with the "Cap"/"Ind" LEDs as sign. - [ind 0.70 .. cap 0.80]

This curve might be used to stabilise the voltage in the local utility area by using the voltage to reactive power characteristics of the local area transformer. E.g. at voltages lower than the lower application point  $360V=400V -10\%$  the controller compensates using a constant  $\cos \phi$  of cap 0.90 due to stimulate voltage rise; between 360V and the upper application point of  $440V=400 +10\%$  the  $\cos \phi$  linearly falls to ind 0.90; at higher voltage above 440V the controller compensates to a fixed  $\cos \phi$  of ind 0.90 due to stimulate voltage fall. Depending on the parameter settings a system for that regulation curve may need inductive reactor steps.!

- PI. 8 Sub menu parameters of regulation curve Q (CI-Signal), general; enter with the "SET" key
- PI.61 Reactive power Q to be left uncompensated in kvar at a CI input current=4mA, negative values are capacitive, positive values inductive
- PI.62 Reactive power Q to be left uncompensated in kvar at a CI input current=20mA, negative values are capacitive, positive values inductive  
Depending on the parameter settings a system for that regulation curve may need inductive reactor steps.!

- PI. 9 Sub menu parameters of regulation curve Q (P), general; enter with the "SET" key
- PI.71 Lower / left application point of the regulation curve in kW
- PI.72 Reactive power Q to be left uncompensated in kvar at the lower / left application point, negative values are capacitive, positive values inductive
- PI.73 Upper / right application point of the regulation curve in kW
- PI.74 Reactive power Q to be left uncompensated in kvar at the upper / right application point, negative values are capacitive, positive values inductive

It does not matter whether both application point reside within the same quadrant I .. IV or reside on two sides around the zero origin, e.g. ind 75 kvar at a maximum injection of -150 kW to cap 50 kvar at a consumption of +100 kW. In this example the controller compensates large injection powers <-150 kW (signed value! negative=injection) with a constant reactive power excess of ind 75 kvar; between -150 kW and +100 kW the uncompensated reactive power linearly rises to cap 50 kvar; at large consumption >+100 kW the controller applies a constant reactive power excess of cap 50 kvar. Depending on the parameter settings a system for that regulation curve may need inductive reactor steps.!

- PI.10 Sub menu parameters of regulation curve Q (U), general; enter with the "SET" key
- PI.81 Lower application point of the regulation curve in V
- PI.82 Reactive power Q to be left uncompensated in kvar at the lower / left application point, negative values are capacitive, positive values inductive
- PI.83 Upper application point of the regulation curve in V.  
The voltages must be input at the voltage level of the mains voltage (e.g. 400V), not at the voltage level of measuring  $U_M$  (e.g. 230V) !
- PI.84 Reactive power Q to be left uncompensated in kvar at the upper / right application point, negative values are capacitive, positive values inductive

This curve might be used to stabilise the voltage in the local utility area by using the voltage to reactive power characteristics of the local area transformer. E.g. at voltages lower than the lower application point  $360V=400V -10\%$  the controller compensates with a constant reactive power excess of ind 75 kvar due to stimulate voltage rise; between 360V and the upper application point of  $440V=400 +10\%$  the cos phi linearly uncompensated reactive power linearly rises to cap 50 kvar; at higher voltage above 440V the controller applies a constant reactive power excess of cap 50 kvar due to stimulate voltage fall. Depending on the parameter settings a system for that regulation curve may need inductive reactor steps.!

#### 5.4.6.5 Menu Series Communication Interface ("PC. ")

The standard variants of the Reactive Power Controller CR4.0 comprises a communication interface: RS485 full duplex for symmetrical twisted pair wiring; please check the termination resistors. The interface may handle baud rates between 1,2 kBaud and 19,2 kBaud, standard is 9,6 kBaud for compatibility with the CR2000M monitor software.

The following protocol stacks are available for selection via Parameter "PC. 1".

PC. 1 Configuration of the communication interface, bit pattern in hexadecimal notation:

The yet available options are:

2000 MODbus similar, proprietary protocol used in the predecessor controller CR2000. As termination partner for trials the PC executable monitor program CR2000M is available.

3117 Big display for the cos phi on LCD modul EA3117

Both protocols use RS485 half duplex, i.e. connect TX and RX in parallel to a single twisted pair wire.

On request other protocol stacks are feasible, if the customer discloses all necessary information (message catalog, flow diagrams, etc.) and holds the necessary licenses.

## 5.5 Alarm Types (Summary)

The software of the Reactive Power Controller CR4.0 handles 59 types of alarms (incl. reserve) plus number 60 that informs about the first alarm with switch-off within an alarm cluster. The following summarising table lists all alarms in use and related alarm parameters including information on settings and their menu items:

Al.-Type	LED or (group)	Prio	Foot note	Alarm Reason / Remarks	Std. value	Range	Menu Items	Foot note
AL. 1	cos phi	1	M	cos phi more inductive than thr.	i0.90	i070-c0.90	P0. 5, PI.22	T1/2
AL. 2	cos phi	0	M	cos phi more cap than threshold	c0.98	i070-c0.90	P0. 6, PI.23	T1/2
				alarm delay AL. 1, AL. 2	60Min	0-1440Min	P0. 7	
AL. 3	(software)	3	R	defect analysis / alarm on step power derating turned off			Pb. 2	
AL. 4	(software)	4	R	maintenance interval expired	16000		SE-Service	
				register "maintenance done"			C0.14	
AL. 8	THDU	2	single	more calculated capacitor current than threshold	130%	105-200%	SE-Service	
AL. 9	(temperat.)	2	M,Ad0	excess temperature expected	fix	AL.24-3°C		
AL.10	U (V)	4	Aso0	zero voltage (short breaks w/o alarm to be counted only)	fix	75% Umains		
AL.11	U (V)	2	Aso2	undervoltage, U < Umin	88%	85-95%	P0.13, Pb. 7	0=SE
AL.12	U (V)	3	Aso1	overvoltage, U > Umax	112%	105-115%	P0.12	0=off
AL.16	U (V)	0	Aso1	undervoltage, U < meter. range	fix	ca. 50V		-HW
AL.17	U (V)	1	Aso1	overvoltage, U > metering range	fix	ca. 780V		-HW
AL.18	I (A)	0	Aso2	overcurrent, I > metering range	fix	ca.8.7A		-HW
				short alarm delay AL.12 .. AL.17	fix	ca. 60ms		
				long Alarm delay AL.10, AL.11, AL.18 ("dead time on Inrush")	5s	0-20s	P0.14	
AL.20	THDU	0	Aso3	single harmonics > threshold	3/6/8%	0; 2%-45%	P0.10	p%
AL.21	THDU	1	Aso3	harmonics THDU > threshold	3/7/9%	0; 2%-45%	P0. 9	p%

AL.-Type	LED or (group)	Prio	Foot note	Alarm Reason / Remarks	Std. value	Range	Menu Items	Foot note
			Aso3	alarm delay harmonics	5Min.	2-20Min.	P0.11	
AL.23	(temperat.)	1	Aso4	frequency > threshold or internally blocked regulation	fix 107%	to nominal frequency	SE-Service	
AL.24	(temperat.)	0	Aso5	excess temperature	48°C	35-65°C	P0.20	
				alarm delayexcess temperature	15Min.	0-240Min.	P0.21	
AL.25	(software)	2	Aso4	low controller supply voltage	fix	internal		
AL.27	(temperat.)	7	Aso4	<b>no alarm</b> ; switched-off due to signal from CI input			PI. 1	
AL.29	(software)	1	Aso6	software error, reset executed				+Info
AL.30	(software)	0	Aso6	"StoP" due to pendular alarms	20 Al.	some free	SE-Service	
AL.31	Step+red		single	step power loss > threshold	20%	5-30%	P0.15	
AL.38	Steps LED			(applies to single steps)				
AL.41	Step+blink.		M	duty period > threshold	80000	10000h- 150000h	P0.16	0=off
AL.48	Steps LED			(applies to single steps)				
AL.51	Step+blink.		M	cycles on/off > threshold	00000	10000- 300000	P0.17	0=off
AL.58	Steps LED			(applies to single steps)				
AL.60			M	AL-No. of the first alarm switch-off within the last alarm cluster				

Table 4 Alarm Types

### Legend

Prio Whithin an alarm group the highest priority is 0. Only the highest priority alarm is displayed

M Alarm message only without effect on regulation and switching

R Alarm Reminder only; is repeatedly displayed with new alarms

Ad0 No alarm delay (=ca. 16s)

single Alarm with switch-off of the affected step(s) only

- Alarms with switch-off of all steps - :

Aso0 Super fast alarm switch-off, ca. 10 .. 20ms; alarm display / counting like Aso2

Aso1 Fast alarm switch-off, ca. 60ms; alarm delay=fix

Aso2 Alarm delay long (for Umin switching step on is blocked after ca. 60ms if not turned-off)

Aso3 Alarm delay for end of switch-off at least 3 times the parameter setting

Aso4 Special alarm delay, internally controlled

Aso5 Additional reasons for switch-off are fast rising temperature and alarm threshold cold.

Continued temperatue rise escalates up to permanent operation stop ("StoP")

Aso6 Error causes an automatic reset; alarm is released after restart

fix Configurable only at SYSTEM ELECTRIC as new SW version or SE-Service

SE-Service Configurable only by authorized service staff, SW version required

0=off Alarm threshold=0 means alarm is turned-off

-HW Consider the HW variants -1A, -100V; the partiicular value depends on calibration

p% Default value depends on the (lowest) detuning factor <2%, <10%, larger

T1/2 Separate alarm thresholds for tariff 1 and tariff 2

+Info In addition information on reason and on thresholds are displayed

Alarm numbers not listed are reserved for future use or internally used (alarm counting, additional information). The operation of the alarm system is described in chapters [3.4 Alarm Switch-off](#) and [3.5 Alarms](#).

## 5.6 General Parameters (Parameter Set I, Summary)

Regulation, metering, alarming, etc. are controlled by the **General Parameters** (parameter set I). The general parameters are self-sufficient and independent from the system using the Reactive Power Controller CR4.0; the system dependent parameters are comprised in the parameter set II and at most setup by commissioning.

Menu Item	Parameter	Foot note	Std. value	Range	SE-Menu	Foot note	my system
<b>Regulation:</b>							
P0. 2	Response time using contactors	-HW	15s	4-3600s	P. 0		
P0.23	Response time using thyristor switches	-HW	00	0; 40-8000ms	P. 1		
P0.25	Response time for contactor switched follower steps in the -4T4K variant	-HW	00	0; 0.1-160.0s	P. 2		
	Delay on direction on/off change of follower steps in the -4T4K variant	-HW	0	0-3600s	P. 3		
	Trigger sensitivity FAST mode	-HW	6	2-32 (arbitr)	P. 4	fix	
	Delay at FAST mode start	-HW	3	0-40 (1/2ms)	P. 5	spec	
	FAST mode re-regulation	-HW	4000=off	0-4000 (1/2ms)	P. 6	spec	
	Surplus power demand on follower steps	-HW	0%	0-50%	P. 7		
<b>Metering:</b>							
	Magnitude of averaging for readings		6	4-8	P. 8	spec	
	Scatter band (german: "Streubreite")		0=autcd	2-52 (arbitr)	P. 9	spec	
	Scatter band, angle (gauging net-config)		40	10-96 (arbitr)	P. 10	fix	
	Scatter band, Excess4		8	4-40 (arbitr)	P. 11	fix	
	Scatter band, Magnitude		8	5-9 (arbitr)	P. 12	fix	
	DELAY_START		0	0-4 (arbitr)	P. 13	fix	
	DELAY_STOP		0	0-4 (arbitr)	P. 14	fix	
	DELAY_ENDE		10	0-50 (arbitr)	P. 15	fix	
	Calm network condition (commissioning)		16	6-600 (1/4P.)	P. 16		
	Max. Cycles for commissioning		14	8-100	P. 17		
	CCHKCNT		200	40-4000	P. 18	fix	
	QCCHKCNT		50	40-1000	P. 19	fix	
P0.28	Test interval for output test (1/2 period)		2.00s	1.00-60.00s	P. 20		
P0.27	Test cycles number for output test		5	1-2000	P. 21		
<b>MMI Man-Machine Interface:</b>							
	POLICY (bit pattern)	List	0000	Bit pattern	P. 22		
Pb. 1	POLICY: capacitive free regulation		off	0002			
Pb. 2	POLICY: <b>suppress</b> defect analysis	invers	off	0800			
Pb. 3	POLICY: <b>no</b> thyristor FAST mode	invers	off	0001			
Pb. 4	POLICY: detail info (commissioning)		off	1000			
Pb. 5	POLICY: <b>no</b> result display (commission.)	invers	off	2000			
Pb. 6	POLICY: contactors switch altogether		off	0080			
Pb. 7	POLICY: contactors switch on U<Umin		off	0020			
Pb. 8	POLICY: cabinet fan on if 1 thyristor on		off	0010			
Pb. 9	POLICY: combi detuning for mixed p%		off	0004			
Pb.10	POLICY: low real power cos phi alarms		off	0100			
	POLICY: <more bits: internal use>			8040			
	Start delay		5s	3-300s	P. 23		

Menu Item	Parameter	Foot note	Std. value	Range	SE-Menu	Foot note	my system
	Timeout keyboard		180s	60-1800s	P. 24		
	Calm readings slow down		1.50s	0.50-4.00s	P. 25		
	LED things timing (std=ca. 1.6s)		16	8-48 (arbitr)	P. 26	fix	
	LED flash timing (std=ca. 0.1s)		25	10-75 (arbitr)	P. 27	fix	
<b>Alarm Configuration:</b>							
	Measuring invalid		400	40-1000 (arb)	P. 28	fix	
P0.11	Alarm delay, harmonics		5Min.	2-20Min.	P. 29		
	Alarm delay, short		0.06s	0.00-20.00s	P. 30		
P0.14	Alarm delay, long (dead time on inrush)		5.00s	0.00-20.00s	P. 31		
	Alarm relay: external alarms (bit pattern)	List	FFFF	Bit pattern	P. 32		
PA. 1	External alarm: cos phi too inductive		on	0001			
PA. 2	External alarm: cos phi too capacitive		on	0002			
PA. 3	External alarm: step power derating		on	0004			
PA. 4	External alarm: duty period (steps)		on	0008			
PA. 5	External alarm: cycles on/off (steps)		on	0010			
PA. 6	External alarm: U<Umin		on	0020			
PA. 7	External alarm: U>Umax		on	0040			
PA. 8	External alarm: U<metering range		on	0080			
PA. 9	External alarm: U>metering range		on	0100			
PA.10	External alarm: I>metering range		on	0200			
PA.11	External alarm: harmonics THDU / 1U		on	0400			
PA.12	External alarm: frequency / regulat.stop		on	0800			
PA.13	External alarm: temperature		on	1000			
PA.14	External alarm: SW error		on	2000			
PA.15	External alarm: reset, different reasons		on	4000			
	Alarm relay: minimum pulse width		30s	2-300s	P. 33		
<b>Alarm Thresholds:</b>							
	Total capacitor current (calculated)		130%	0; 105-200%	P. 34	0=off	
	Capacitor voltag (calculated) <free>				P. 35		
P0. 9	Harmonics THDU	p%	3/7/9	0; 2.0-42.0%	P. 36	0=off	
P0.10	Single harmonics 1U	p%	3/6/8	0; 2.0-42.0%	P. 37	0=off	
P0.13	Umin in % f. Umains; (0=off Pwd spec!)		88%	0; 85-95%	P. 38	0=off	
P0.12	Umax in % from Umains		112%	0; 105-115%	P. 39	0=off	
	<free>				P. 40		
	<free>				P. 41		
P0.15	Step Power derating		20%	5%-30%	P. 42		
P0.17	Duty period in h*100		800	0; 100-1500	P. 43	0=off	
P0.16	Cycles on/off in *100		1000	0; 100-3000	P. 44	0=off	
	Pendular alarms or resets		20	0; 10-999	P. 45	0=off	
	Maintenance interval in h*100		160	0; 80-1500	P. 46	0=off	
	<free>				P. 47		
<b>Cos phi Parameters</b>							
P0. 7	Alarm delay cos phi		60Min	0-1440Min.	P. 48		
	<free>				P. 49		
P0. 4	Target cos phi, tariff 1		1.00	i0.70-c0.80	P. 50		
PI.21	Target cos phi, tariff 2		i0.95	i0.70-c0.80	P. 51		
P0. 5	Alarm cos phi, inductive, tariff 1		i0.90	i0.70-c0.80	P. 52		
PI.22	Alarm cos phi, inductive, tariff 2		i0.90	i0.70-c0.80	P. 53		

Menu Item	Parameter	Foot note	Std. value	Range	SE-Menu	Foot note	my system
P0. 6	Alarm cos phi, capacitive, tariff 1		c0.98	i0.70-c0.80	P. 54		
PI.23	Alarm cos phi, capacitive, tariff 2		c0.98	i0.70-c0.80	P. 55		

Table 5 General Parameters, Parameter set I

**Legend** (not-user-relevant parameters have been skipped!)

-HW Consider HW variants, -8K, -4T4K, -4T resp. RS485 interface version -S

List Input by selection within a list, "Pb. ", or "PA. "

invers Please remind the inverse wording !

p% Default values change acc. the lowest detuning factor, ranges <2%, <10%, above

fix Do not change!, changeable at SYSTEM ELECTRIC only, or "spez"

spec Changeable with special passwords only by authorized service stat or by SE itself

0=off Parameter=0 means that functionality is turned-off

0=auto Parameter=0 means that functionality is controlled by the controller itself

(arbitr) Parameter value in arbitrary units, e.g. internal power digits

The function "revert to standard settings" ("In. 1" during normal operation) reverts the parameter set I only to (customized) factory defaults but does not change the parameter set II that comprises data setup by commissioning.

## 5.7 System-specific Configuration Parameters (Parameter Set II, Summary)

At delivery the System-specific Configuration Parameters (parameter set II) are set "unknown" for parameters entered via commissioning resp. to their default values. In a factory pre-programmed controller the parameters representing the system where the controller is mounted have been input by hand. Then the second part of commissioning only checks that parameters after the still missing parameters had been collected by the first part of commissioning. The parameter set II comprises the following parameters:

Menu Item	Parameter	Foot note	Std. value	Range	SE-Menu	Foot note	my system
<b>Communication Interfaces:</b>							
	Parameter 1 (RS485: Mode)				P. 56		
	Parameter 2 (RS485: Baudrate)				P. 57		
	Parameter 3 (RS485: Parity)				P. 58		
	Parameter 4 (RS485: Pause)				P. 59		
	Parameter 5 (RS485: Delay)				P. 60		
	Parameter 6 (RS485: Address)				P. 61		
PC. 1	Parameter 7- Interface Type		0000	Bit pattern	P. 62		
<b>Control Interface (CI):</b>							
PI. 1	Interface Configuration CI		0000	Bit pattern	P. 63		
<b>Special Regulation II:</b>							
	KNICK_1_ZIEL	intern			P. 64		
deri-	KNICK_1_QUELLE	intern			P. 65		

Menu Item	Parameter	Foot note	Std. value	Range	SE-Menu	Foot note	my system
ved	KNICK_2_ZIEL	intern			P. 66		
from	KNICK_2_QUELLE	intern			P. 67		
PI.21	KNICK_3_ZIEL	intern			P. 68		
to	KNICK_3_QUELLE	intern			P. 69		
PI.99	KNICK_4_ZIEL	intern			P. 70		
	KNICK_4_QUELLE	intern			P. 71		
<b>Special Regulation I:</b>							
P0. 8	Fixed compensation power / basic load		0	like step power	P. 72		
P0.22	Limitation of steps powers sum		832%	104%-832%	P. 73		
In. 3	SE mode	List	0=aus	0;"SE"	P. 74		Init
	optivar mode		0=aus	0;2;3;4	P. 75		Init
St.xx	Fixed steps (" On")	List	0000	Bit pattern	P. 76		Init
St.xx	Off steps (" OFF")	List	0000	Bit pattern	P. 77		Init
In. 6	End stop steps		0000	Bit pattern	P. 78		Init
St.xx	Inductive steps	List	0000	Bit pattern	P. 79		Init
<b>Temperature Parameters:</b>							
P0.19	Cabinet fan on temperature		0	25-40°C	P. 80		
	Minimum fan on/off time		30s	10-300s	P. 81		fix
P0.18	Temperature alignment cabinet / sensor		0°C	-10-+10°C	P. 82		
P0.20	Excess temperature switch-off		48°C	35-65°C	P. 83		
P0.21	Alarm delay excess temperature		15Min	0-240Min.	P. 84		
	Restart temperature hysteresis		13°C	5-20°C	P. 85		fix
	Excess temp. advance warning (delta)		3°C	1-15°C	P. 86		fix
	Excess temperature cold		-10°C	-15-+10°C	P. 87		fix
<b>System Configuration, Hardware:</b>							
P0. 3	Idle period after contactor switch off	-HW	45.0s	3.0-300.0s	P. 88		
P0.25	Idle period after thyristor switch off	-HW	00	0.02-90.00s	P. 89		
	Contactor switch on time (incl 1 repeater)		40ms	25-2000ms	P. 90		
	Contactor switch off time (incl 1 repeater)		40ms	25-2000ms	P. 91		
	Thyristor switch on time		25ms	8-100ms	P. 92		
	Thyristor switch off time		25ms	8-100ms	P. 93		
	Folow-up period on		50ms	0-2000ms	P. 94		
	Folow-up period off		50ms	0-2000ms	P. 95		
	Tracking switching operation, magnitude		5	4-6	P. 96		fix
	Cluster point analysis, members		10	9-14	P. 97		fix
	Cluster point analysis, average		30	20-140	P. 98		fix
	<free>				P. 99		
P0.30	Fixed frequency (0=auto: measured by tracking voltage curve)		0= auto	0; 45.00-65.00Hz	P.100		spec
	Nominal frequency (internally fixed during gauging the net configuration)	intern		4.00-66.00Hz	P.101		intern
	Alarm threshold Freuency		07.0%	01.0-130.0%	P.102		fix
	Alarm delay frequency alarm		12	4-300 (arbitr)	P.103		fix
<b>System Configuration, Net Config.:</b>							
In. 9	Measuring voltage, terminal 1		will be		P.104		Init
In. 9	Measuring voltage, terminal 3		fixed		P.105		Init
In. 9	Measuring current, phase		by		P.106		Init
In. 9	Measuring current, transducer sense or system dependent phase angle		gau- ging		P.107		Init



Menu Item	Parameter	Foot note	Std. value	Range	SE-Menu	Foot note	my system
In.10							
	Catenation (internally fixed, input possible e.g. for AC operation)	intern	net conf.		P.108	Init	
In.11	Nominal mains voltage (at the capacitor bank; meas. voltage x1 or xSQRT(3)		at Init		P.109	Init	
	<free>				P.110	Init	
	Alarm threshold zero voltage	fix	75%	20-90%	P.111	Init	
<b>System Configuration, Transducer:</b>							
	Voltage transducer, ratio or primary	0=nix	0	1-9999	P.112		
	Voltage transducer, secondary	0=nix	0	50-700	P.113		
P0. 1 In. 5	Current transducer, ratio or primary (input also via "In. 4", "PI.24")	0=nix	0	1-9999	P.114		
In. 4	Current transducer, secondary	0=nix	0	1; 5	P.115		
P0.26	Phase error correction for transducers		-45'	-900-+900'	P.116	spec	
PI.25	Current transducer, primary (2 <sup>nd</sup> transd.)		0=off	0; 1-9999	P.117		
	<free>				P.118		
PI.26	Current transducer, secondary (2 <sup>nd</sup> trd.)		-45'	-900-+900'	P.119		
<b>Syst. Conf., Transducer sec. Overload:</b>							
	IMAX_IMAX	intern			P.120		
P0.29	IMAX_UEBERLAST (0=new estimation)		intern	0=restart	P.121		
	IMAX_BASE	intern			P.122		
	IMAX_STEP	intern			P.123		
	IMAX_CNT	intern			P.124		
<b>Input Prototypes for Other Parameter:</b>							
	Detuning, input area	intern			P.125		
	Double parameter, 1 <sup>st</sup> input value	intern			P.126		
	Double parameter, 2 <sup>nd</sup> input value	intern			P.127		

Table 6 Configuration Parameters, Parameter Set II

**Legend** (not-user-relevant parameters have been skipped!)

-HW Consider HW variants, -8K, -4T4K, -4T resp. RS485 interface version -S

List Input by selection within a list, "Pb. ", or "PA. "

fix Do not change!, changeable at SYSTEM ELECTRIC only, or "spez"

spec Changeable with special passwords only by authorized service stat or by SE itself

0=off Parameter=0 means that functionality is turned-off

0=auto Parameter=0 means that functionality is controlled by the controller itself

0=nix Parameter=0 means that this parameter is virginal

intern Internal use by the controller itself; do not change that value

Init Changeable only during the initialisation phase, mostly be commissioning!

Beyond the parameter set II there are other configuration settings not presentable as table. Regarding the functionality "revert to (customised) factory defaults" those settings are handled the same. They are:

Steps powers Qc0 holds per step the initially sized or input step power in internal power digits

Steps powers Qc holds per step the actual lastly measured step power in internal power digits

## User/Service Password

The parameter set II can be cleared using the "revert to (customised) factory defaults" functionality (= "In. 1" during commissioning mode) that also clears the parameter set I (= "revert to standard values"). Hence a new commissioning process is necessary afterwards.

The following configuration settings firmly accompany the controller HW. They are set by the controller production:

Calibration settings                      Calibration of internal digits to externally readings

Serial numbers

HW/SW variantes

The min/max values of readings, the "use and wear data" of the steps (e.g. cycles on/off), and the alarms are also not handled as parameters. Most of them can be reset using action menu items (e.g. "C0.12"=reset harmonics maxima).

## 6 Application Notes

### 6.1 FAQ

#### Classification of the Reactive Power Controller CR4.0

- Is the CR4.0 better than his predecessors, better than competitive controllers?

Substantially the CR4.0 is identical to its predecessor CR2020 but with a microprocessor system two generations newer. Some features of seldom use have been removed (e.g. acoustical signal, reset min/max readings in small groups). Instead several practically useful features have been amended (e.g. fix steps, steps out of service, end stop step for commissioning). Enthusiastic users of the CR2020 will so sadly miss regulation with target range cos phi due to reduce switching cycles, listing changed parameters, and the integrated operating manual / helping hints, e.g. the acceptance range at data input.

The current measurement of the CR2020 was more sensitive as compared with its predecessor CR2000 by a factor of about 4. At the CR4.0 that advantage is shrunk to 3 to the benefit of a higher overload current. Even more sensitive competitor controllers are very seldom; for special regulation tasks you must wait for the next controller generation, e.g. for compensating small reactive power in whole a local distribution system.

There are only few competitor controllers with more features than the CR4.0. SYSTEM ELECTRIC uses such controllers for their compensation systems e.g. if a communications interface is required.

In combination with the SYSTEM ELECTRIC thyristor switch CT2000 the controllers CR2020 and CR4.0 in Fast Mode offer an ultra-fast response time of 25msec to the first leap in net situation and 40msec for the next response. That is not familiar to most other controller / thyristor switch combinations which require heat dissipating fast-discharge resistors due to achieve only re-connection times of several hundreds of milli seconds.

- Note that the Reactive Power Controller CR4.0 supersedes its predecessor controllers CR2020 and CR2000.

SYSTEM ELECTRIC always provides only one own controller type series. For special purposes some CR2020 will be available until exhaustion, e.g. for very big systems in the MVA range exceeding the CR4.0 display size.

## 6.2 What to do, if . . .

### Public Utility

- I have to **pay for reactive energy** in spite of an existing compensation system.

The multiplicity of contracts between public utility and customers prevents from any statement in common. Please disclose your contract and a few latest invoices due to get valuable advice from your utility or from SYSTEM ELECTRIC. For a detailed report consult a professional agency.

For contracts with peak power measurement either by electronic electricity meter or old-fashioned by an electricity meter with a drag indicator and quarterly retraction the total compensation power has to be so large that at any moment the minimum required cos phi (often Ind 0.90) will be achieved. With the CR2020 the user had been able to reduce the system's wear by programming a wide target range cos phi (e.g. Ind 0.90- 1.00) with the target cos phi near the inductive border (e.g. Ind 0.93). On cos phi alarm fast reaction is required (e.g. Ind 0.90- 1.00, alarm delay 0.25h). Sadly the target range feature has been removed in the CR4.0.

Often the public utility uses for "small" customers separate electricity meters for the active energy and for the reactive energy. Those meters sum up the kWh and the kvarh until the next readout one month later but do not correlate that measures momentarily based on the respective power peaks. Thus a compensation system may be so small that insufficient cos phi values at times of high load may be balanced by super cos phi values during times of medium load. Here the target cos phi has to be set to 1.00 (in CR2020 also target range 1.00- 1.00) and the cos phi alarm should be ignored (e.g. by an alarm delay of 12h).

With an own power generation and own consumption or self consumption prior to feeding excess energy into the mains the amount of purchased active energy drops - thus drops the limit of reactive energy free of charge. Due to avoid charging for reactive energy the customer must amend his compensation system with finer steps. Or the customer is delighted to get much more subsidies than as complete feeder, much more than the reactive power fee.

### Compensation System Configuration

- In thr past SYSTEM ELECTRIC equipped their big compensation systems with a mechanical bi-metal switch due to control cabinet ventilation from the air column near the capacitors. Compact systems only and nowadays cabinets also use the Reactive Power Controller CR2020 resp. CR4.0 for the **control of the cabinet / compact case fan**.

- The **granularity** of a capacitor bank (i.e. the ratio between smallest and largest steps powers sizes) must not exceed 1:16. Usually no more than 1:4 or 1:8 is required.
- Your public utility **meters electricity at the medium-high voltage** but the current transducer of the compensation system resides in the low voltage.

Program a capacitive **fix compensation power / basic load** (menu items "P0. 8" or "In.14"; transformer size - typ. fix compensation: 250kVA - 5kvar, 400kVA - 7,5kvar, 630kVA - 12,5kvar, 1250kVA - 25kvar) for compensation of the **transformer's reactive load on idling**. Additionally consider the dynamical reactive load by shifting the target cos phi by 0,01 to 0,02 towards capacitive, but this is not usually done.

Note: If the current transducer for the compensation system itself resides in the medium-high voltage power supply no action is required because the transformer is already included in compensation.

- The customer premises is **feed by two or more transformers** that in any way may be coupled.

1. At redundant transformers the crosspoint is ahead of the current transducers and the sub-distributions access points. This is identical to the standard configuration.

2. If the section switch(es) divides the electricity net into several autonomous sub-networks every one needs its own compensation system. If each compensation system is affected by only one section switch the 3-transducer solution very effectively solves that configuration: Use a transducer at any connection to the (sub-) network equal whether feeding or consumptive and subtract / add all particular secondary currents using an adequate summarizing transducer, please ask SYSTEM ELECTRIC for that solution.

When coupling network sections with separate compensation systems they must have different response times due to avoid oscillations by more than one responding compensation system leading to demand for readjustment .

3. Moreover the new CR4.0 software offers a special scaling method for exactly 2 identical transformers. The external Control Interface (CI) is connected to the status signal from the section switch. Set the option "Dual Feeder (,inverted)" in the CI configuration menu item "PI. 1" and use parameters "PI.24" to "PI.26" for setting the real and the virtual transducer configuration for the mostly used / extra section switch states. Note that the SW is not restricted for identical transformers but inaccuracy increases with the differences in transformers because of non-linear effects.

The menu item "PI.27" is designed to automatically enter the method 3 parameters by commissioning. For this the section switch has to be really switched! Instructions: At first perform commissioning using the mostly effective setting of the section switch (because of the higher precision of measurement). Then (or before) configure the

dual feed option in "PI. 1" considering the not inverse / inverse option of the control signal. Now toggle the section switch to its extra position (for the less accuracy measurement). Start the "PI.27" action with "SET". That procedure needs a few minutes when started in the commissioning mode but will also work in automatic regulation mode but needs some hours due to let compensation work almost without artefacts. Please note that the controller itself may change the control signal inversion on end of transducer gauging.

When coupling network sections with separate compensation systems they must have different response times due to avoid oscillations by more than one responding compensation system leading to demand for readjustment .

- The customer uses a **Network Management System**:

Use the alarm relay to inform the network management about problems in the compensation system. Observe the right polarity NO / NC of the relay contact. Use the "PA " menu group to exclude trouble reasons from being reported to the network management.

If a communication based connection to the network management system is required you must use a competitive controller or you must wait until the CR4.0 comprises that feature.

- **Steps using contactors in follow-up configuration or with lag:**

The method inside the CR4.0 SW to measure the own steps sizes considers one follow-up level using an auxiliary contact at the first contactor. If your capacitor bank uses more follow-up levels or lagged half-electronic contactors you must adjust the timing parameters "P. 90" and "P. 91" using the SE special password. Please ask service staff authorized by SYSTEM ELECTRIC for that settings.

- **Thyristor Switched Capacitor Bank (Dynamic Regulation):**

Due to compensate fast fluctuations in the mains network you can use the hardware variants -8T, -8T-E, -4T4K, or -4T4K-E of the Reactive Power Controller CR4.0 for thyristor switches. Like its predecessor CR2020 the CR4.0 is able to generate the control signals for a set of thyristors within 15msec in Fast-Mode (or even faster with parameter optimization). In conjunction with the thyristor switch CT2000 from SYSTEM ELECTRIC fluctuations in mains network may be answered within 25 / 35msec (switch on / off) and compensated within 60 / 70 msec including all swing in bounces. Within 45msec a readjustment operation or even a new regulation is possible without any needs for fast discharge with power resistors.

For use of slow competitive thyristor switches the timing parameters may be optimized. The idle time must be adjusted using menu item "P0.24" (about 3.50s for capacitors with standard discharge resp. 0.10s with fast discharge by power resistors).Where necessary also the switching time parameters have to be adjusted which requires the SE password. Please ask SYSTEM ELECTRIC for the adjustments.

- **Thyristor Switched Capacitor Bank using the -4T4K variants (Mixed Dynamic Regulation):**

The following rules apply to dimensioning: The total steps power of thyristor switched steps should sum to 150% (at least 130%) of the required dynamical power swing because it could take up to 45s (standard) idle time if a contactor has to be reenergized. The power of the smallest contactor step should equal to the second largest thyristor step, e.g. thyristors 1:2:4:8, contactors 4:8:8:8.

- The mains network comprises big asymmetrical loads: Use per phase a separate compensation system with L-N AC configuration. All 3 controllers have to be programmed for AC operation: Set catenation "P.108"==1 prior to commissioning using the SE special password. Please ask service staff authorized by SYSTEM ELECTRIC for that setting.

## Steps

- **Smallest Step Power** (value of thumb without transducer U):

Measure Voltage **L-L**    **5var**, 1var (-1A), 2.5var (-100V), 0,5var (-1A-100V)

Measure Voltage **L-N**    **9var**, 2var (-1A), 3.5var (-100V), 0,8var (-1A-100V)

each x current transducer ratio; in gentle mains,  
with troubled mains up to 5 times more required!

-1A, -100V= HW variants of the CR4.0

Using thyristor switches in (half-) dynamic Systems requires about 4 times larger smallest steps because of the fast, light averaging methods.

Please contact SYSTEM ELECTRIC for a complete calculation at special requirements in well known (network analysis) mains, also with transducer.

- The **Largest Step Power** depends on the mains network size as composed from the controller's components, the calibration, the transducers, and the net configuration (L-L or L-N). Please contact SYSTEM ELECTRIC for a complete calculation at special requirements. As value of thumb multiply the smallest step power by 2000 for the maximum size of a single step, or by 8000 for the maximum power of all steps.

The simplest method to check whether the Reactive Power Controller CR4.0 fits into your system is to try it on-site. The CR2020 told you the minimum and maximum applicable step sizes with the support texts on input of a step size or the fixed compensation power. The CR4.0 controller shows the minimum and maximum applicable step sizes at menu item "C0.19" for repair / step replaced or added prior to select the step number. That applies also to commissioning mode where that menu item cannot be started.

- **Verifying the Steps Powers:**

On every switching action on or off the Reactive Power Controller CR4.0 analyzes the response of the mains network. Using up to three slightly different methods the difference in reactive power before to after the switching action gives a single value for the reactive power of the switched step. By extensive statistical calculations many single values result in the measured step power to be display in menu item "S2.yy" with yy=step number. Usually together with periodical maintenance by an expert this method is enough to ensure that steps work as desired.

The maintenance staff themselves should prefer the only reliable method to measure the step size: Use a clamp amperemeter to measure the current in all three phases (thumb value: 50kvar gives 72A) and correct it by the square of voltage to nominal voltage if the actual voltage is far beyond its nominal value (the CR4.0 ever shows steps powers corrected to nominal mains voltage and to nominal frequency). Using Manual Mode you can switch on / off every step even those defective or not existing.

- In few mains environments the **Steps Powers** measured by the CR4.0 are **heavily fluctuating** and as a result **steps go offline tagged as defective**. But with the clamp amperemeter no defect can be found at all.

At first check the measurement prerequisites: Is the current transducer directly connected to the controller with no other device in series and, of course, no other device in parallel? Is the current transducer overloaded at secondary side? Does the current transducer see all currents from all feeders to the loads? Is no feeder among the loads (no feed from the rear)?

If the measurement prerequisites are in order the only method to carry on without defective steps is stop the defect analysis for steps: menu item "Pb. 2"=on. from then on you yourself is responsible for detecting power loss at the steps by periodical measurement with the clamp amperemeter (suggestion: every second month); the CR4.0 reminds you with the info alarm "AL. 3" and repeats that alarm together with every new alarm. Note that only the analysis of defects is off; the controller still measures the steps sizes from its point of view and shows them in the "S2.yy" menu series.

- You want to take a **step temporarily offline** while in normal operation ? Use menu item "St.yy" in the menu tree "Set" to switch the step type of step number yy between "OFF" and the type defined at commissioning.

## **Regulation Method, Switching Action**

- **Not any Regulation into Capacitive Cos Phi**

Usually the customer is admitted an excepted quantity of reactive energy in relation to his purchased electricity equal whether inductive or capacitive. But



some public utility companies charge every capacitive energy regardless of excepted quantities (e.g. in switzerland). The regulation strategy of the Reactive Power Controller CR4.0 can be fitted to that cases: Either switch on the capacitive-free regulation (menu item "Pb. 1"=on) or program an inductive fix compensation power / basic load in size of the smallest capacitive step ("P0. 8") thus getting a regulation characteristics shifted in parallel towards the inductive.

- For **fast compensation** of big machines set the response time ("C0. 5" or "P0. 2") to a smaller value (min. 4s) and additionally enable contactors for switching together ("Pb. 6"=on).
- **Compensate Single Elevator Rides** or quite not:  
With a small response time (min. 4s) the compensation system responses still during the ride and compensates the reactive power used for that single ride. Experience shows that the mains net remains silent and more balanced if you do not compensate single rides of an elevator but compensate the mean of all elevator rides. Here it would be best to increase the response time ("C0. 5" or "P0. 2") to about 1 minutes. This also reduces wear of the compensation system.

## Operation

- **The Password Protection shall take effect immediately**, not in 3 minutes when I have left the customer premises: Enter a wrong password in menu item "change password" ("C0. 9").

## Common Maintenance

- The Reactive Power Controller CR4.0 requires no periodical care. All electronic devices should ever be handled with care.
- Wipe stained cases with a moist cloth, not with a wet one! If you suspect also stained interior call the service for cleaning the whole system.
- The power supply of the controller's electronic is intended for continuous operation in stable mains networks (europe). Frequent power blackout or frequent overvoltage stress reduce the power supply's lifespan. Please contact SYSTEM ELECTRIC prior to use the CR4.0 in such mains networks.
- If the controller had been fallen down from desktop or higher don't use the controller anymore. Please contact SYSTEM ELECTRIC before returning the controller for repair

## Maintenance

- *(applies only if ventilation is controlled by the CR4.0)*  
If the maintenance operation is **troubled by the fan's air flow** use menu item "C0.10" to stop ventilation for 30 minutes. Prematurely ventilation may be re-activated by the fan test ("C0.15").

## 6.3 Appendix

### 6.3.1 Graphical Representation of the Menu Trees

<to be completed>

### 6.3.2 Characters and Texts at the Numerical 7-Segment Display

"0" .. "9", "A", "b", "C", "d", "E", "F"	Numbers in decimal / hexadecimal
"1" / "I"	Number "1" uses the right segments, letter "I" the left ones
"0000"	(duty period, cycles on/off, etc.) Reset to 0
"04..."	Cycles counter, here at start of the 4 <sup>th</sup> cycle
" -"	unpopulated, not existent
" -.-"	(yet) no actual value
". . . "	(continuation mark ...)
"=SEt"	Start the action displayed before by the "SET" key, e.g. "ALL.H" / "0000" / "=SEt" reset all harmonics maxima to 0, start with SET
"≡≡≡≡"	(horizontal bars ciel and floor) Number exceeds the display capacity (make shift at SW error; should never be displayed)
"-AL-"	Operation sub-mode Alarm Switch-off (=all steps off)
"AL..."	Pending alarms, not shown after having been acknowledged
"AL. _"	Alarm, any type
"AL.19"	Alarm type 19
"ALL "	... all ...
"ALL.A", "ALL.H", "ALL.M"	All min/max values of the alarm counts, harmonics, measurement readings
"APPr"	(Commissioning:) Please approve the displayed results
"Auto"	Operation mode Automatic Regulation
"bArE" / "dAtA"	This menu will show the actual bare data at the connector strip
" CAP"	Capacitive (also step type)
"ConF"	(Commissioning:) Connection to the mains network, "net data"
"Cont"	Relay output driving <u>C</u> ontactors, step type at variant 4T4K
"COS.I", "COS.P", "COS.U"	Operational sub-mode of the CI input interface / of regulation: cos phi (CI signal/P/U) curve
"dIgI"	Operational sub-mod of the CI input interface: digital
"donE"	(operation, action completed, is finished)
"EEA "	Operational sub-mod of the CI input interface: Power generator (german: <u>E</u> nergie- <u>E</u> rzeugung- <u>A</u> nlage) using cos phi (P) regulation acc. to VDE AR-N-4105 (2007)
"Err "	ERROR, e.g. "Pwd " / "Err " password error at password input
"Err.4"	error number 4 (at commissioning only)
"FACT." / "dEF.S"	Revert all settings or commissioning data to the <u>F</u> actory <u>D</u> efaults, thereafter new commissioning is required
"FAn "	Fan
"HAnd"	(Commissioning:) Enter the connection to mains ("ConF") or ther steps powers ("StEP") numerically by hand
"I.ctr"	Current "I (A)" <u>t</u> ransducer <u>r</u> atio
"I.ovr"	Secondary ssded overload of current transducer (comissioning)

"I.tot"	Total current "I (A)" (at commissioning)
" I=0"	No load, "I (A)" (nearly) 0 Ampere
" Ind"	Inductive (also step type)
"InFo"	Information, parameter detail info, menu tree "Info"
"InIt"	Operation mode Initiation / Commissioning
"LEw "	Operational sub-mode of the CI input interface, regulat. curve cos phi (CI signal) acc. to LEW specification (12mA=cos phi 1.00)
" MAn"	Operation mode Manuel
"ModE"	Operation mode, e.g. "ModE" / "InIt" Op. mode (Re-) Commissioning
"ModE" / "Std. "	(Commissioning:) Commissioning in Standard Mode (not SE Mode)
"ModE" / "SE "	(Commissioning:) Commissioning in SE Mode (not Standard Mode)
" OFF", "OFF-", "=OFF."	Off, (as step type:) step out of operation, is switched off
" On", "= On."	On, (as step type:) (semi-) permanent step, is switched on
"OncE" / "MorE"	(Outputs Test:) Operate test once more
"PARA." / "dEF.S"	Revert to <u>Parameter Defaults</u> , parameter set I only
"Per " / "StEP"	Menu item applies to any step, start with SET, select step by "→"
"Pwd ", "Pwd="	Password, password entry
"Pwd.1", "Pwd.2"	New password, 1 <sup>st</sup> and 2 <sup>nd</sup> copy (password repetition)
" -Pwr" / "OFF-"	(Outputs Test:) Power off? (confirmation query)
"SELF"	Automatic, <u>Self-acting</u> Commissioning
"SEt ", "SEt-"	"SET" key, set parameter, menu tree "Set"
"StEP"	(Commissioning:) Step of the capacitorbank, steps power
"StoP"	Operation mode Out of Service (Stop)
"SurE" / " to " / "Abrt."	Sure to abort? (confirmation query)
"t1 ", "t2 "	Tariff 1 / Tariff 2, (note on target cos phi at green "Auto" / "cos phi" LED)
"tEst"	Operation mode Outputs Test
"tHYr"	Transistor output driving <u>thyristor</u> switches, step type shown at variant 4T4K only
"tYPE"	Type, steps type
"vAr.I", "vAr.P", "vAr.U"	Operational mode of the CI input interface / regulation: reactive power kvar (CI signal/P/U) curve
"WAIt"	Please wait

## 6.4 Contact to the Manufacturer

The Reactive Power Controller CR4.0 is manufactured in responsibility of:

SYSTEM ELECTRIC Power Quality GmbH	
Altenhasslau	Gewerbegebiet Hailer-Ost
Odenwaldstrasse 4	Zum Sonnenberg 5
63589 Linsengericht	63571 Gelnhausen
Germany	Germany

Phone: +49 (0)6051 74158  
FAX: +49 (0)6051 71093  
E-Mail: [info@system-electric.de](mailto:info@system-electric.de)  
Internet: [www.system-electric.de](http://www.system-electric.de)

Commercialregister Amtsgericht Hanau, HRB 13324  
Managing Director Klaus Holbe

<b>Contents</b>		<b>Page</b>
<b>0</b>	<b>Bibliography</b>	<b>3</b>
<b>0.1</b>	<b>Disclaimer</b>	<b>3</b>
<b>0.2</b>	<b>Scope</b>	<b>3</b>
<b>0.3</b>	<b>Version History</b>	<b>3</b>
<b>0.4</b>	<b>File</b>	<b>3</b>
<b>1</b>	<b>Installation</b>	<b>4</b>
<b>1.1</b>	<b>Safety Instructions</b>	<b>4</b>
<b>1.2</b>	<b>Installation Diagram</b>	<b>4</b>
Figure 1	Installation Diagram: Compensation of Classical Loads, only	4
<b>1.3</b>	<b>Connection Diagram</b>	<b>5</b>
Figure 2	Connections to the Reactive Power Controller CR4.0	5
	Please note that pin numbering corresponds to the markings at controller and connector strip rather than to the marking in the connector datasheet !	5
<b>1.4</b>	<b>Mechanical Installation</b>	<b>6</b>
<b>1.5</b>	<b>Hints</b>	<b>6</b>
Table 1	Maximum cable length between current transducer and cabinet	7
<b>2</b>	<b>Commissioning</b>	<b>9</b>
<b>2.1</b>	<b>Automatic Self Commissioning</b>	<b>9</b>
2.1.1	Automatic Self Commissioning in Standard Mode	10
2.1.2	Automatic Self Commissioning with a Pre-programmed Controller	10
2.1.3	Pre-programming the CR4.0 (SE-Mode)	11
2.1.4	Non-Standard Compensation Systems	12
2.1.5	Special Settings or Guidelines	12
<b>2.2</b>	<b>Experts Menu</b>	<b>13</b>
<b>2.3</b>	<b>Error Codes and Tips</b>	<b>13</b>
<b>3</b>	<b>Normal Operation</b>	<b>15</b>
<b>3.1</b>	<b>Automatic Regulation Mode</b>	<b>15</b>
3.1.1	Regulation Algorithm	15
3.1.2	Switching Algorithm	16
3.1.3	Response Time, Response Time Dynamics	16
3.1.4	Idle Period	17
<b>3.2</b>	<b>Manual Mode</b>	<b>17</b>
3.2.1	Enter the Manual Mode	17
3.2.2	Manually Switch Steps (Action Menu)	18
3.2.3	Temporarily leave the Manual Mode	18
3.2.4	Standard Screen in Manual Mode	18
3.2.5	Screens shown in Manual Mode	19

3.2.6	Terminate the Manual Mode	19
3.2.7	Reset in Manual Mode	19
<b>3.3</b>	<b>Out of Operation (STOP)</b>	<b>20</b>
<b>3.4</b>	<b>Alarm Switch-off</b>	<b>20</b>
<b>3.5</b>	<b>Alarms</b>	<b>21</b>
<b>4</b>	<b>Operations</b>	<b>22</b>
Figure 3	Front Panel of the Reactive Power Controller CR4.0	22
<b>4.1</b>	<b>Controls</b>	<b>22</b>
4.1.1	LED Menu Ribbons	23
4.1.2	Numerical 7-Segment Display	24
4.1.3	Keyboard	25
4.1.4	Number entry, item selection	26
<b>4.2</b>	<b>Standard Screen</b>	<b>27</b>
<b>4.3</b>	<b>Information Retrieval (Menu Tree "Info")</b>	<b>28</b>
<b>4.4</b>	<b>Programming (Menu Tree "Set")</b>	<b>29</b>
<b>5</b>	<b>Detailed View</b>	<b>31</b>
<b>5.1</b>	<b>Technical Data</b>	<b>31</b>
<b>5.2</b>	<b>LED Ribbons in Detail</b>	<b>32</b>
5.2.1	Left sided, Vertical LED Ribbon	32
5.2.1.1	Green "Auto" LEDs and yellow "Service" LED "ΔQc": Direct Presentation of a Measured Value	32
5.2.1.2	Yellow "Service" LEDs: Action LEDs	33
5.2.1.3	Red "Alarm"-LEDs: Alarms	33
5.2.2	Horizontal "Steps" LED Ribbon, green and red	34
<b>5.3</b>	<b>Menu Tree "Info" in Detail</b>	<b>34</b>
5.3.1	Basic "Info" Group acc. Code Table ("C1. ")	34
5.3.2	"Info" Menu Group Measurement ("M . ")	36
Table 2	Measurement Values of the "Info" Group "M . "	37
5.3.3	"Info" Menu Group Harmonics ("H . ")	38
5.3.4	"Info" Menu Group Steps ("S . ")	38
5.3.5	"Info" Menu Group Alarms ("A . ")	39
<b>5.4</b>	<b>Menu Tree "Set" in Detail</b>	<b>40</b>
5.4.1	Password Protection	40
5.4.2	Legend on Parameter Input	40
5.4.3	Basic "Set" Group acc. Code Table ("C0. ")	41
5.4.4	"Set" Menu Group Initiation ("In. ")	42
Table 3	Pin Assignment versus system dependent Phase Angle	44
5.4.5	"Set" Menu Group Steps ("S . ")	45
5.4.6	"Set" Menu Group Parameter ("P . ")	47
5.4.6.1	Menu Series Alarm Relay Parameter ("PA. ")	47
5.4.6.2	Menu Series Binary Policy Parameter ("Pb. ")	48
5.4.6.3	Menu Series Common Parameter ("P0. ")	49

5.4.6.4	Menu Series Control Interface (CI) ("PI. ")	54
5.4.6.5	Menu Series Communication Interface ("PC. ")	58
<b>5.5</b>	<b>Alarm Types (Summary)</b>	<b>59</b>
Table 4	Alarm Types	60
<b>5.6</b>	<b>General Parameters (Parameter Set I, Summary)</b>	<b>61</b>
Table 5	General Parameters, Parameter set I	63
<b>5.7</b>	<b>System-specific Configuration Parameters (Parameter Set II, Summary)</b>	<b>63</b>
Table 6	Configuration Parameters, Parameter Set II	65
<b>6</b>	<b>Application Notes</b>	<b>67</b>
<b>6.1</b>	<b>FAQ</b>	<b>67</b>
+	Classification of the Reactive Power Controller CR4.0	67
<b>6.2</b>	<b>What to do, if . . .</b>	<b>68</b>
+	Public Utility	68
+	Compensation System Configuration	68
+	Steps	71
+	Regulation Method, Switching Action	72
+	Operation	73
+	Common Maintenance	73
+	Maintenance	74
<b>6.3</b>	<b>Appendix</b>	<b>74</b>
6.3.1	Graphical Representation of the Menu Trees	74
6.3.2	Characters and Texts at the Numerical 7-Segment Display	75
<b>6.4</b>	<b>Contact to the Manufacturer</b>	<b>77</b>



SYSTEM ELECTRIC Power Quality GmbH  
 Odenwaldstraße 4  
 63589 Linsengericht, Germany  
 Internet: [www.system-electric.de](http://www.system-electric.de)

Tel.: +49 (0) 6051-74158  
 Fax: +49 (0) 6051-71093  
 E-Mail: [info@system-electric.de](mailto:info@system-electric.de)