

Just That Easy: Reactive Power Compensation using the Controller CR4.0

Installation:

Attach 230V AC to the U_B power supply pins 5/6 (in any order) of the 24-pin long connector strip. Separately connect the U_M voltage measurement pins 1/3 to the capacitor bank feeding (L-L delta voltage any phase, any order). At three-phase systems with 400V AC you may alternatively bridge U_M to U_B to measure the 230V L-N star (wye) voltage. Attach the current transducer to the I_M current measurement pins 8/9 (in any order); remove the current transducer short (if any). Now half the work is done - the controller CR4.0 is empowered to gauge the net configuration.

One after another attach the branch lines to the capacitor bank to the outputs K1 to K8, pins 11 to 18 of the connector strip (in any order). Attach the phase pole of the 230V AC supply for the contactors inside the capacitor bank to the COM common output pin 10 (-8K controller variant: or COM2, pin19) and the corresponding neutral to the return paths from the contactors. Now the Reactive Power Controller CR4.0 hardware is ready to compensate the reactive currents in your system by activating the capacitors of the bank.

Commissioning:

When powering up (turn in the controller fuse resp. switch on the circuit breaker) all lamps of the Reactive Power Controller CR4.0 light for a few seconds (lamp test). Then the controller is ready for commissioning. The green LED "U (V)" lights and the numerical 7-segment display shows the voltage actually measured. By the arrow down "↓" key you may proceed to the next LED "I (A)" to display the actual current through the current loop transducer <--> controller (0..5A). The numerical display is blinking because the current transducer ratio (ctr) is still unknown (the shown value bases on 5A:5A).

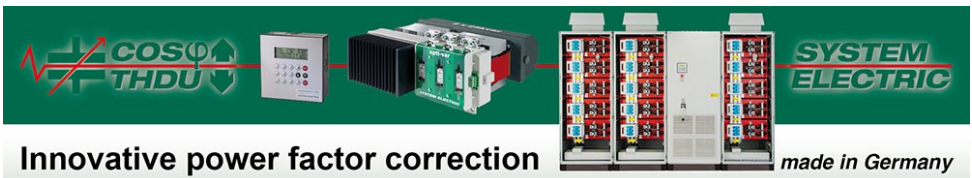

Start the Automatic Self Commissioning process by a long keystroke (3 seconds) on both green arrow keys " \downarrow " and " \rightarrow " (=reset) or by selecting the "Set" menu item "**In. 2**", activated by keystroke on "**SET**". While the commissioning process is running the CR4.0 controller switches several times steps of the capacitor bank. It determines from the changes in strength and phasing of current and voltage the net configuration as well as the capacitors reactive powers. That process may take about 5 to 15 minutes. In the meantime the controller displays clocked in sequence "**SELF**" / "**InIt**" / "...".

Commissioning is finished when the displayed sequence changes to "**SELF**" / "**InIt**" / "**donE**" followed by lighting all lamps during change to the Automatic Regulation Mode via reset.

If not turned off the sequence "**SELF**" / "**InIt**" / "... " is two or three times intercepted by displaying the results of the commissioning process each starting with "**APPr**" (for "approve!"); for details refer to the Menu Structure (short form guide) resp. to the chapters in the verbose Operations Instructions manual. You may speed up the result display by " \rightarrow " or stop it by "**SET**".

If you want to track the single actions of the commissioning process you may select that prior to process start ("detail info"). Refer to the verbose detailed Operating Instructions manual. It also comprises the statements necessary for non-standard commissioning.

Automatic Regulation Mode Operation:

While compensating the reactive power in automatic mode operation your controller CR4.0 shows the resulting power factor $\cos \phi$ at the numerical 7-segment display. The green LED "**cos phi**" indicates that all works nice. The more the $\cos \phi$ approaches 1.00 the less your mains is stressed by reactive current. But note that at low active load the power factor $\cos \phi$ may achieve any value without relevance because the reactive power is low, too; low load conditions are indicated by no or only one small capacitor being switched on.

The green "Steps" LEDs show which steps of the capacitor bank are actually switched on.

During automatic mode operation the mains conditions and the system utilization are tracked by the controller. That gives an extensive collection of actually measured values with their minimum and maximum to be displayed using the menu tree "Info". The menu tree "Set" offers a multiplicity of settings due to adapt operation, error detection and alarming to your requirements.

SYSTEM ELECTRIC Power Quality GmbH

Author: Werner Weisgerber, english language corrected by Timo Huikuri

Installation Manual Reactive Power Controller CR4.0

0 Bibliography

0.1 Disclaimer

This document was written by Werner Weisgerber on behalf of SYSTEM ELECTRIC Power Quality GmbH, Linsengericht, Germany;
Copyright ibid.

0.2 Scope

This document applies to Software Version 02.05 et seqq.
Edition A5, last change 2019-07-08

0.3 Version History

Edition A5	2019-07-08	Adaptation to menu structure 02.05
Edition A4	2019-03-06	Text reworked, enhanced figures, paragraphs "Controller Variants ..." and "Technical Data" new
Edition A3	2019-02-12	New banner
Edition A2	2018-12-20	English Language corrections; SW01.02
Edition A1	2018-10-26	First Publication

0.4 File

Name of the original file: CR40_EN_Installation_0205_A5 as .doc and .pdf

1 Installation

1.1 Safety Instructions

Skilled technical staff only is permitted to mount, connect and commission this reactive power controller. Consider all relevant regulations.

In case of visible or assumable damages this controller must not be operated. Only the manufacturer is allowed to repair.

This controller is energized by mains voltage and must not be opened. Please note that the clamps can be energized although the regulator is off.

1.2 Installation Diagram

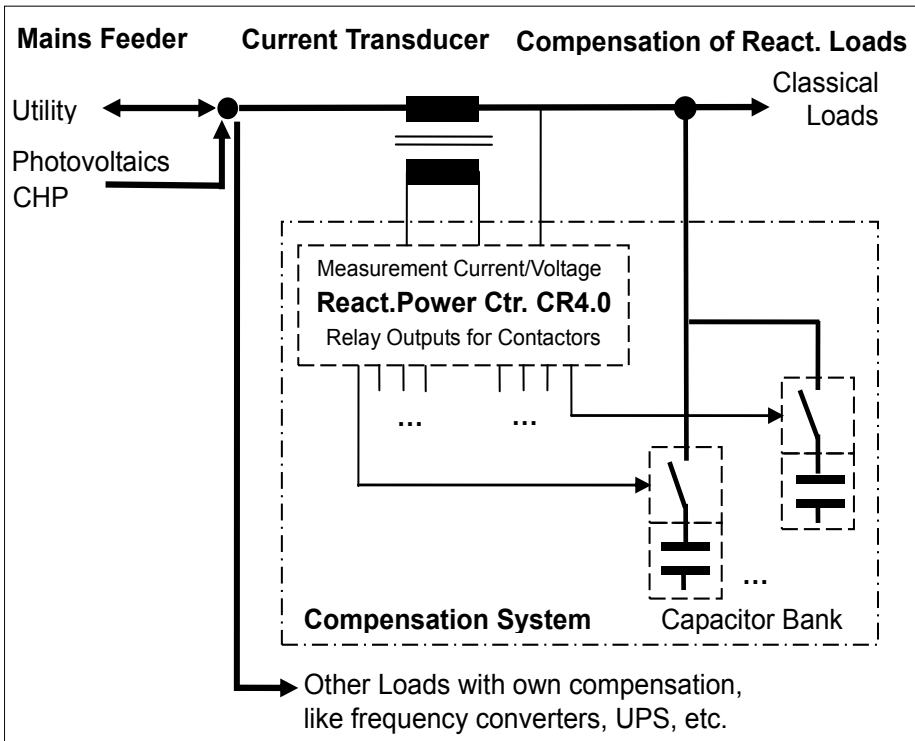

Figure 1

Installation Diagram: Compensation of Classical Loads, only

1.3 Connection Diagram

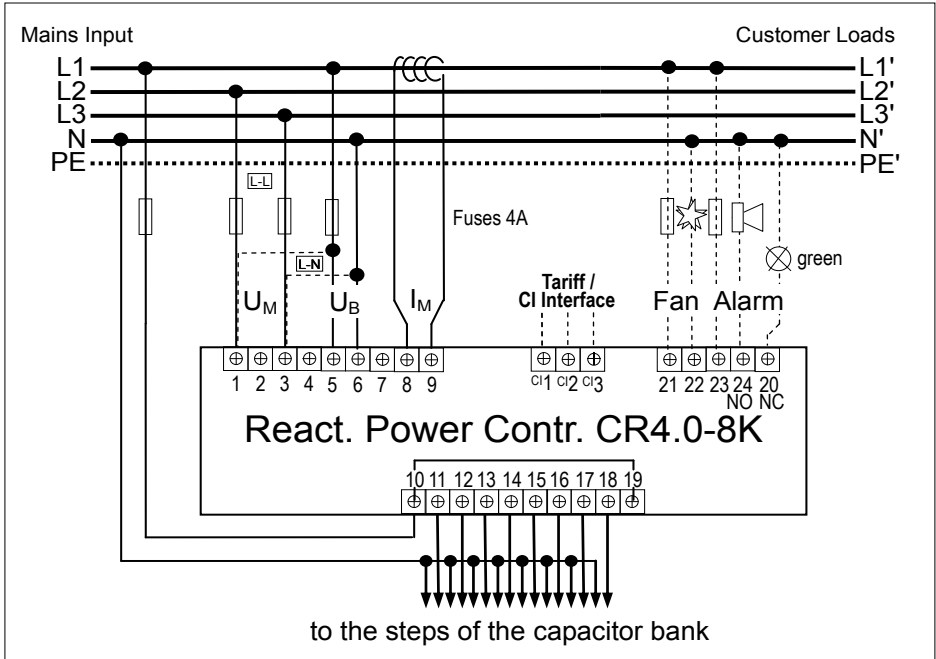

Figure 2 Connections to the Reactive Power Controller CR4.0
 Please note that pin numbering corresponds to the markings at controller and connector strip rather than to the marking in the connector data sheet !

Figure 2 shows the L-L standard connection diagram. Despite of single-phase current measurement it provides detection of short break at every phase. Short break in phase L1 results in outage of the controller itself by loss of supply. On short break in phase L2 or L3 the controller detects loss of measuring voltage. In every case all steps of the capacitor bank will be immediately switched off due to protect the capacitors from re-connection in phase opposition. Before re-connection the capacitors are discharged during the idle period. Furthermore the response sensitivity of the CR4.0 with L-L measurement is higher by square root of 3 resp. the smallest step power is reduced by that factor.

Please do not feel discouraged to use the simple L-N connection method. Lacking the quoted L-L advantages will be compensated by simplified wiring using bridges for phase and neutral directly at the connector strip. The common pin COM for the contactors should not be included in bridging because of the impacts on measured voltage during contactor switching; even though experience says that no negative effect results on compensation but harmonics may be recognized slightly increased.

1.4 Controller Variants (Outputs)

Besides the standard variant CR4.0-8K of the Reactive Power Controller providing 8 relay outputs to drive contactors there are the (half) dynamic variants CR4.0-4T4K and CR4.0-8T available with transistor outputs to drive thyristor switches, e.g. CT-2000 from SYSTEM ELECTRIC.

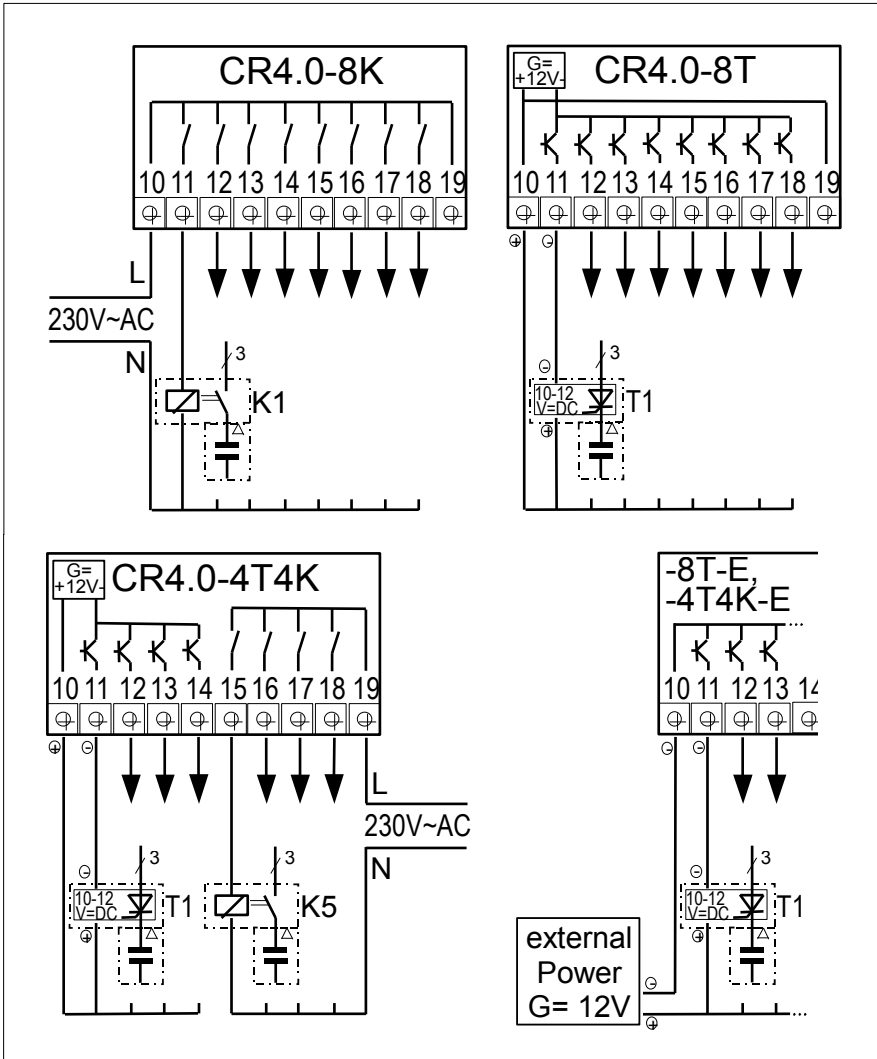

Figure 3 Output Variants of the Reactive Power Controller CR4.0

1.5 Controller Variants (Measuring)

Besides the standard variant of the Reactive Power Controller CR4.0 intended for a to-5A current transducer and for a measuring voltage in the range of 58V AC .. 700V AC (nominal voltage) there are special variants available, "-1A" for to-1A current transducers and for the "-100V" interface, suitable for to-100V medium voltage transducers, and plus the combined variant "-1A-100V". That special variants provide a higher resolution by factor 5/2.5/12.5. All that variants have to be manually modified, please consider some days extra for your order.

Smallest Step Power (thumb values for -8K contactor switched steps, w/o transducer U):
 measuring voltage **L-L** **12var**, 2,5var (-1A), 5var (-100V), 1var (-1A-100V)
 measuring voltage **L-N** **21var**, 5var (-1A), 9var (-100V), 2var (-1A-100V)
 each case x ctr (current transducer ratio)

Using the CR4.0 variant -8K those characteristics values apply to **most mains networks even with high disturbances**. In very rough electrical environment the smallest step power may be required to be up to 3x higher. Very patient networks may accept down to half of those values. For the regulation with **thyristor** switched steps (CR4.0 variants -8I, -4T4K) factor at least 4x higher smallest step values because averaging is not such strong here.

1.6 Mechanical Installation

The Reactive Power Controller CR4.0 houses in a panel-mounting case acc. DIN IEC 61554 with a nominal size of 144mm x 144mm.

Usually the Reactive Power Controller CR4.0 is installed into a control panel or into an **opening 138mm x 138mm** within the door of an electrical cabinet or a compact enclosure. An installation depth of 60mm results using a 90° sideways cabled terminal block connector strip. The housing is locked in the opening by screwed brackets at the left and at the right side.

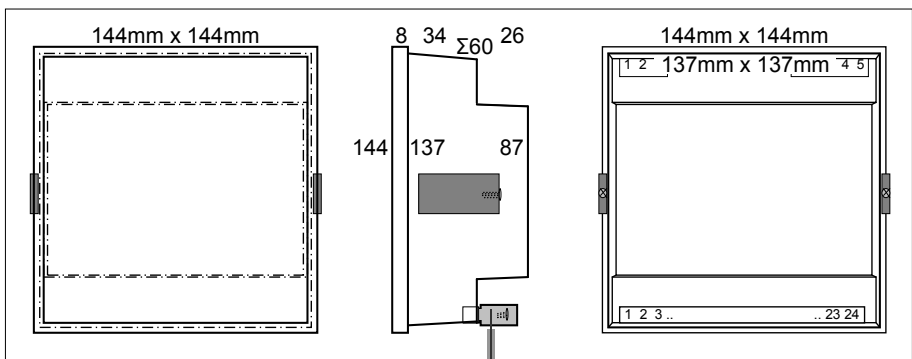

Figure 4 View to the housing from the front, the side and the rear

On request you may order gasket rings, or transparent covers with or without door lock.

For DIN-rail installation use the housing variant with the "-H" part identifier.

1.7 Hints

- Use **measurement transducers of class 1** or better with enough electrical power.
- The **current transducer** must be placed in-between all left sided feeding equipment and all right sided load equipment including the compensation system itself, see [Figure 1 Installation Diagram](#) on page 4. Loads comprising their own compensation (e.g. frequency converters, uninterruptible power supply UPS, etc.) should not be included in the reactive power compensation.
- **Short bridge unconnected secondary current transducer terminals** when primarily loaded due to protect transducer and service staff from overvoltage harm. Remember to remove the short before controller (re-) activation. General technical regulations suggest single-sided earthing of current transducers at low voltage.
- Consider to use the **adequate output power and the adequate cable cross-section** for the current transducer

At current measurement the Reactive Power Controller CR4.0 consumes 0.3VA at 5A from an internal resistance (burden) of 12mOhms (at the -1A variant 90mVA at 1A, 90mOhms). With a maximum of 2.1m cable of 1.0 mm² inside the SYSTEM ELECTRIC cabinet the cable from the current transducer must not exceed (values in brackets for the -1A variant):

cable cross-section	2,5VA-transducer	5VA-transducer	7,5VA-transducer	10VA-transducer
1,5 mm ²	- (100 m)	4,0 m (210 m)	9 m (320m)	13 m (420 m)
2,5 mm ²	- (170 m)	7,5 m (350 m)	15 m	21 m
4 mm ²	-	12 m	24 m	35 m
6 mm ²	-	19 m	36 m	53 m

Table 1 Maximum cable length between current transducer and cabinet including 2,1m 1.0mm² (values in brackets for the -1A variant)

The Reactive Power Controller CR4.0 itself is able to handle **secondary-sided transducer overload**, when the system ran for a while with correct load and the overload is creepingly incurred, e.g. by added small machines.

- When using a **summarizing transducer** the transducer ratio to be programmed in the CR4.0 has to be calculated from the sum of all primary nominal current values divided by the secondary nominal current value of the

summarizing transducer. E.g. using two current transducers 1200A:5A and a summarizing transducer 5A+5A:5A gives a setting of 1200A+1200A:5A=2400A:5A resp. the ctr ratio 480.

- Measurement bases on analyzing the current and voltage curves versus time. Therefore the accuracy suffers from EMC crosstalk particularly if the common phase for the contactors in the capacitor bank is bridged at the connector strip with the measurement voltage pins. Please **use separate cables for voltage measurement** up to the power bus bar.
- When using **phase shifting components** in the measurement circuits (e.g. old mechanical amperemeter, summarizing current transducer, standard transformer instead of voltage transducer) the resulting measurement fault may be partly corrected by adjusting the parameter "phase error", which at standard is preset for one class 1 current transducer an no voltage transducer.

Note! A transformer to facilitate 230V AC for the contactors or as controller power supply must never be used also as voltage transducer because the fluctuating load results in measurement errors by phase and amplitude shifts. Please connect the voltage measurement directly to the power bus bar, use a dedicated voltage transducer, or at least use a separate transformer.

- The measurement circuits as well as the controller's power supply cope with small overvoltages / overcurrents. Due to increase the robustness against heavily fluctuating or high slew rate signals you may attach filtering circuits. The attenuating and phase shifting qualities of that filters must be considered (adjust transducer ratios and phase error parameters). When adding a filter into an operational system please perform new commissioning afterwards.
- **Reactive Power Compensation and Emergency Power Supply:** Usually it is recommended that a stationary emergency power plant should not be stressed by a reactive power compensation. The diesel generator itself is able to provide any reactive power needed. For this the emergency power plant has to be connected at the right side of the current transducer, see [Figure 1 Installation Diagram](#). Then the reactive power compensation plant automatically idles when the emergency power plant takes over from the utility feeder.

Emergency power supply from the public utility is accomplished using an increased frequency (51Hz / 61Hz). Here it is not intended to switch off the reactive power compensation plant. If your utility company claims switch-off the SYSTEM ELECTRIC service staff can change the internal alarm parameters for frequency accordingly.

- The Reactive Power Controller CR4.0 is designed to compensate the reactive current of **classical passive loads**.

Loads with their own reactive power compensation (e.g. UPS, frequency converters) can incur mismeasurement when monitoring the steps powers of

the own capacitor bank leading to switch-off of single steps as defective. Monitoring the steps powers by the fault analysis is detachable, but you must adopt this task by yourself !

If you have **power generators** (e.g. a photovoltaic plant) installed with the loads **on the right side** of the current transducer (see [Figure 1 Installation Diagram](#)) the Reactive Power Controller CR4.0 is not able to see the current between the loads-sided generators and the loads resp. the capacitor bank. Misregulation and particularly switch-off of steps after wrong steps powers measurement may result. Please correct your installation (it would anyway not be accepted by your utility company nor by the subvention authority).

If the correct installation is not possible or not desired use a second current transducer in front of the generators and a summarizing transducer to charge the difference current into the CR4.0. That avoids misregulation but you must try out whether fault analysis / steps powers measurement has to be detached. In special cases when the generator feeds only active power without reactive contributes you may try the EEA mode in CI menu of the Reactive Power Controller CR4.0.

- Low voltage systems with **two or more feeder systems**:

With all feeder and the section switches at the left of the current transducer and all loads to be compensated and the compensation system itself at its right side, see [Figure 1 Installation Diagram](#) a standard compensation system fits.

The 6-transducer-method allows every reactive power controller to handle separate systems using an own reactive power compensation system per transformer but with a section switch in-between. Install each current transducer at the transformer and at the section switch and use a summarizing transducer for charging the controller. For 2 transformers this sums to 6 transducers. Use different response times for the compensation systems to avoid mutual oscillations.

With two identical transformers and with the status of the section switch as tariff input to the Control Interface (CI) programming the CI allows the CR4.0 to handle that system with only one current transducer per subsystem. Assuming the current is equally distributed in the system the CR4.0 handles two different transducer ratios as a function of the section switch state.

Please ask SYSTEM ELECTRIC for (alternative) solutions.

- The Reactive Power Controller CR4.0 is not especially designed for use in **isolated networks**, in particular not for networks with a regulation strategy differing from that of the public utility. Usage for that cases is at own risk resp. works on agreement with SYSTEM ELECTRIC (e.g. fishing ships, oil rigs).

1.8 Technical Data

Measuring System

Type of measuring system	single phase, electronic
<u>Measuring Voltage</u>	58V..700V AC (<u>-100V variant</u> 50V..250V AC), maxx, 780V AC
Resolution	raw approx. 1,0V (0,4V); filtered approx.0,2V (0,1V)
Accuracy	repeat accuracy approx. 0,6%; abs. approx. 1,5%
Input impedance	high impedance, <50 μ A
Fusing	max. 4A
Harmonics	Fourier analysis, filtered 1. .. 31. harmonics
<u>Measuring Current</u>	0 .. 5AAC, max. 7.7A (<u>-1A variant</u> 0 .. 1AAC, max. 2A)
Resolution	raw approx. 10mA (2mA); filtered approx. 3mA (1mA)
Accuracy	repeat accuracy approx. 0,6%; abs. approx. 1,5%
Input impedance	0,3VA q 5A =12m Ω (90mVA @ 1A =90m Ω)
Harmonics	Fourier analysis, filtered 1. .. 31. harmonics
	Regulation bases on the filtered measuring readings (<u>-8K</u>) resp. on the raw measuring values (<u>-8T</u> , <u>-4T4K</u>)
Frequency Range	45Hz .. 65Hz (lock-in range); 41Hz .. 69Hz (pull-in r.)
Temperature Measur.	about -20°C ... +70°C

Power Supply

Supply Voltage	230V AC, 50/60Hz
Power consumption	<15VA
Fusing	max. 4A
Ambient Temperature	-10°C .. +60°C

Steps Outputs

Number of Outputs /	8, Relays for contactors (<u>-8K</u>) or Transistors for
Output Types	thyristor switches (<u>-8T</u>), in variant <u>-4T4K</u> mixed
Smallest Step Power	<u>-8K</u> : 12var (L-L), 21var (L-L) x ctr (current transducer ratio)
<u>Relay Output</u>	for contactors: 250V AC, max. 4A, in total max. 4A
Fusing	max. 4A
<u>Transistor Output</u>	for thyristor switches 10V DC, max. 150mA (single / Σ)
external power supply	(<u>variants -E</u>) 8..16V DC (abs.max. 20V), Σ max. 1.2A
<u>Alarms / Fan relay</u>	250V AC, max.4A
Fusing	max.4A

Panel Mounting

Case / Panel Opening	Panel-mounting case 144mm x 144mm acc. DIN IEC 61554 / Opening: 138mm x 138mm
Case Depth	60mm

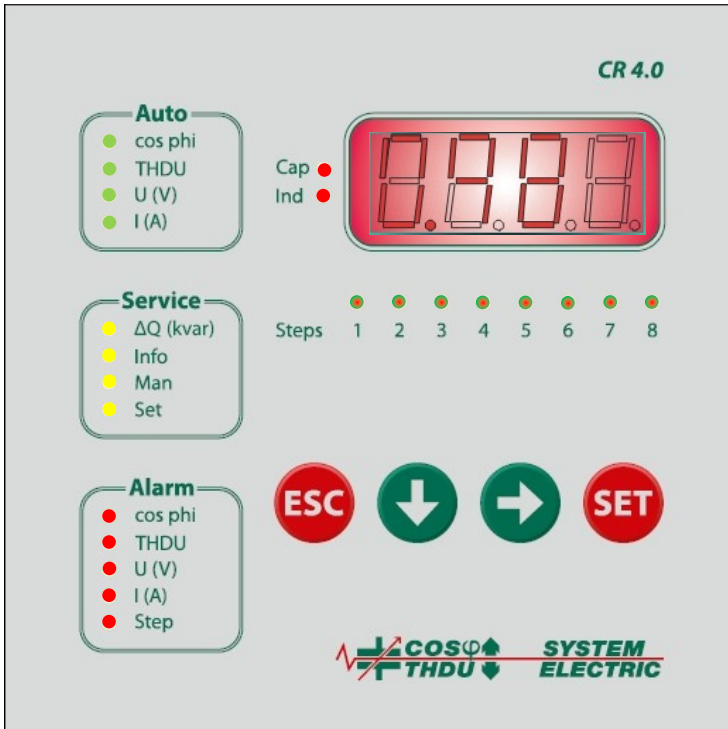

Figure 5

Front Panel of the Reactive Power Controller CR4.0

SYSTEM ELECTRIC
Power Quality GmbH

Gewerbegebiet Hailer-Ost
Zum Sonnenberg 5
63571 Gelnhausen
Germany

Tel.: +49 6051 74158
Fax: +49 0605 71093
www.system-electric.de
info@system-electric.de

